



Excellent
Oil & Gas
Solutions



Safety Hammer™
Operating and Maintenance Instructions



TABLE OF CONTENTS

SAFETY INFORMATION	2
PLACING SAFETY HAMMER IN SERVICE.....	2
USING THE SAFETY HAMMER.....	2
GENERAL INFORMATION	3
OVERVIEW.....	3
IDENTIFICATION.....	3
PLACING SAFETY HAMMER IN SERVICE.....	3
MAINTENANCE.....	4
ASSEMBLY/DISASSEMBLY OF SAFETY HAMMER.....	4
REPLACEMENT OF IMPACT TOOL.....	4
OPERATION	5
OVERVIEW.....	5
INSTALLATION EQUIPMENT, ACCESSORIES AND SPECIFICATIONS.....	5
USING THE SAFETY HAMMER.....	6
PARTS LIST.....	6
TROUBLE SHOOTING GUIDE.....	7

SAFETY INFORMATION



IMPORTANT SAFETY INFORMATION ENCLOSED. READ THIS OPERATING AND MAINTENANCE INSTRUCTIONS MANUAL BEFORE OPERATING PRODUCT.

IT IS THE RESPONSIBILITY OF THE EMPLOYER TO PLACE THE INFORMATION IN THIS MANUAL INTO THE HANDS OF THE OPERATOR. FAILURE TO READ, UNDERSTAND AND FOLLOW THE OPERATING AND MAINTENANCE INSTRUCTIONS MANUAL COULD RESULT IN SEVERE PERSONAL INJURY OR DEATH.

PLACING THE SAFETY HAMMER IN SERVICE

- It is critical that, since most Weir SPM products generate, control or direct pressurized fluids, those who work with these products be thoroughly trained in their proper application and safe handling. It is also critical that these products be used and maintained properly.
- Always operate, inspect and maintain this product in accordance with American National Standards Institute Safety Code for Portable Air Tools (ANSI B186.1).
- For safety, top performance, and maximum durability of parts, operate this product at 90 psig (6.2 bar/620 kPa) air pressure at the inlet with 1/2" (13 mm) inside diameter air supply hose with 3/8" NPT male thread plug and 1/2" hose barb coupler.
- Always turn off the air supply and disconnect the air supply hose before installing, removing or adjusting any accessory on this product.
- Always turn off the air supply and disconnect the air supply hose before performing any maintenance on this product.
- Do not use damaged, frayed or deteriorated air hoses and fittings.
- Be sure all hose connections are tight. A loose hose not only leaks but also can come completely off the product and while whipping under pressure, can injure the operator and others in the area. Attach safety cables to all hoses to prevent injury in case a hose is accidentally broken.
- Be sure all hoses and fittings are the correct size and are tightly secured.
- Always use clean, dry air. Dust, corrosive fumes and/or excessive moisture can ruin the motor of this product.

- Do not lubricate product with flammable or volatile liquids such as kerosene, diesel or jet fuel.
- Do not clean any parts with diesel fuel. Diesel fuel residue will ignite in the product when it is operated, causing damage to internal parts.
- Use only proper cleaning solvents to clean parts. Use only cleaning solvents which meet current safety and health standards. Use cleaning solvents in a well ventilated area.
- Do not remove any labels. Replace any damaged label.
- The use of other than genuine Weir SPM replacement parts may result in safety hazards, decreased product performance, increased maintenance, and invalidate all warranties.
- It is a personal responsibility to visually inspect each union connection prior to each use for damage, unusual or excessive wear, excessive hammering, cracks, wash or erosion, corrosion or etching, thread or seal damage or other abnormalities. Any questionable component should be removed from service and submitted to a thorough inspection.

USING THE SAFETY HAMMER

- When using this product, safety glasses, hearing protection, approved safety shoes, hard hats, and any other appropriate protective clothing must be worn. Hammering on unions may cause sparks and foreign material to become airborne.
- Do not carry product by the hose or adapter.
- Do not indulge in horseplay. Distraction can cause accidents.
- Keep hands and fingers away from the throttle lever until it is time to operate the product.
- Never rest the product on your foot.

- Never point the product at anyone.
- Never start the product when it is lying on the ground.
- Take care when setting the product down to prevent accidental operation.
- Compressed air is dangerous. Never point an air hose at yourself or co-workers. Never blow clothes free of dust with compressed air.
- Never disconnect a pressurized air hose. Always turn off the air supply and bleed the product before disconnecting a hose.
- Keep hands, loose clothing and long hair away from impacting end of product.
- Anticipate and be alert for sudden changes in motion during start up and operation of product.
- Keep body stance balanced and firm. Do not overreach when operating this product. High reaction torques can occur at or below the recommended air pressure.
- Product may continue to impact briefly after the throttle is released.
- Product can vibrate in use. Vibration, repetitive motions or uncomfortable positions may be harmful to your hands and arms. Stop using product if discomfort, tingling feeling or pain occurs. Seek medical advice before resuming use.
- Never operate product unless it is assembled properly and the product is held firmly against the wing nut.
- This product is not designed for working in explosive atmospheres.
- This product is not insulated against electric shock.
- Excessive hammering on nut can damage both product and hammer unions.
- Personnel should never hammer on unions or treating pipe when pressure is present.
- Always keep personnel away from flow lines while under pressure.
- Assembly of unions with Safety Hammer should be done by persons qualified to do so either by training or reading and understanding the manual. Training is available on a regular basis from Weir SPM. Contact Weir SPM at 1-800-342-7458 for more information.
- Product should not be assembled by anyone other than personnel specifically trained in Weir SPM Procedures.
- The use of pressurized components in oilfield operations is inherently dangerous. Personnel working around energized equipment and flow lines should use extreme care and observe all applicable safety precautions. Proper use of this equipment can reduce but not eliminate the risk of severe personal injury or death.

Weir SPM has determined that the Safety Hammer, when used in accordance with these recommended practices, will produce adequate make-up and break-out power.

It is important to note that operating conditions will differ among service companies and their procedures. Type and technique of operations vary drastically around the world. Customers must evaluate their specific application and establish procedures and proper maintenance to guarantee that connections are properly assembled. Weir SPM is available to provide guidance, but the end-user of the equipment has ultimate say and responsibility on how it is applied.

GENERAL INFORMATION



It is critical that, since most Weir SPM products generate, control or direct pressurized fluids, those who work with these products be thoroughly trained in their proper application and safe handling. It is also critical that these products be used and maintained properly.

OVERVIEW

The Safety Hammer is designed as an alternative to the sledge hammer when working with hammer union products used within the oil and gas industry. The Safety Hammer eliminates the hazard of swinging a hammer to make up or break down a hammer union connection.



Figure 1. Safety Hammer Assembly

IDENTIFICATION

The Safety Hammer products are permanently identified on each component. All Safety Hammers have full traceability and are identified by their VENDOR ID (Weir SPM), and PART NUMBER.



Figure 2. Safety Hammer Label

PLACING THE SAFETY HAMMER IN SERVICE

The pneumatic device is coated inside and out with rust-resisting oil before leaving the factory. Before using the Safety Hammer, remove this oil by pouring about 6cc of WD40 or equivalent cleaning solution into the air inlet and attach the air hose. Insert a tool into the Safety Hammer and while holding the tool against a relatively solid object such as a plank or timber; operate the Safety Hammer for about 4 seconds. Dry the pneumatic device immediately after cleaning, pour 3 cc of air tool oil into the air inlet and again operate the Safety Hammer for 5 seconds to lubricate all working parts.

Always use an air line lubricator with the Safety Hammer. We recommend the C28231-800 Ingersoll Rand Filter-Lubricator-Regulator Unit or equivalent:

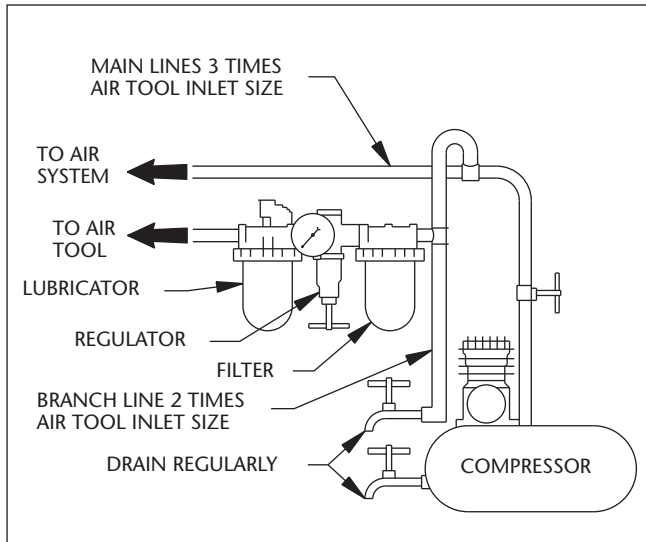

Figure 3. Recommended Piping Arrangement

Before attaching the air hose, place about 3 cc of air tool oil into the air inlet. This should be done each day, even when an air line lubricator is used. During the working day, check the Safety Hammer to ensure that the retainer components are lubricated. After each two or three hours of operation, if an air line lubricator is not used, disconnect the air hose and pour about 3cc of air tool oil into the air inlet of the Safety Hammer. If the action of the Safety Hammer becomes sluggish, pour about 3 cc of a suitable cleaning solution into the air inlet and run the Safety Hammer for 4 seconds. Immediately after flushing the Safety Hammer, pour about 3 cc of air tool oil into the air inlet and run the Safety Hammer for about thirty seconds to lubricate internal parts. Before storing the Safety Hammer or if the Safety Hammer is to be idle for a period exceeding twenty-four hours, pour about 3 cc of air tool oil into the air inlet and operate for 5 seconds to coat the internal parts with oil.

MAINTENANCE



Always wear eye protection when operating or performing maintenance on the Safety Hammer. Always turn off the air supply and disconnect the air supply hose before installing, removing, or adjusting any accessory on the Safety Hammer or before performing any maintenance on the Safety Hammer.

a.) Lubrication:

Each time the Safety Hammer is disassembled for maintenance and repair or replacement of parts, pour about 3 cc of air tool oil in the air inlet and operate the safety hammer for 5 seconds to coat the internal parts with oil. Weekly, flush the Safety Hammer and lubricate immediately afterwards as instructed in PLACING THE SAFETY HAMMER IN SERVICE.

b.) Repair of Pneumatic Device:

If pneumatic device experiences a loss of power, efficiency or ceases to operate completely, please contact your nearest Weir SPM Service Center or Weir SPM Fort Worth for instructions.

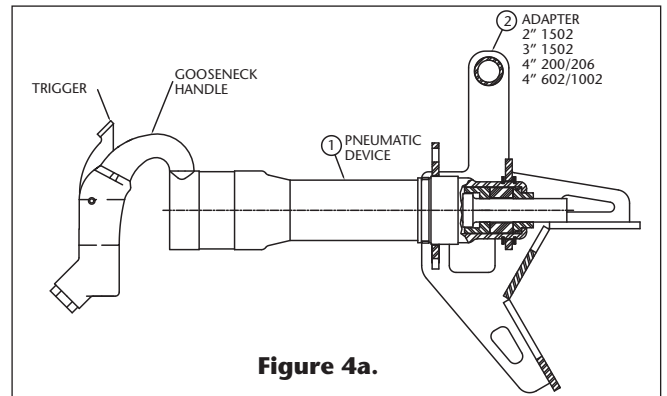

Figure 4a.

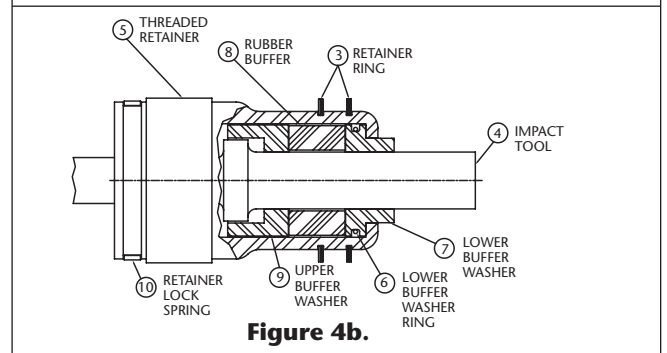

Figure 4b.

Figure 4. Safety Hammer Parts List

ASSEMBLY/DISASSEMBLY OF THE SAFETY HAMMER

The below instructions detail the suggested steps in properly assembling the Safety Hammer.

1. Insert the following parts inside the Threaded Retainer (5) as shown in Figure 4b.
 - Split Lower Buffer Washer (7) with Ring (6)
 - Solid Rubber Buffer (8)
 - Split Upper Buffer Washer (9)
 - Impact Tool (4)
2. With parts ((4), (6) - (9)) positioned inside Threaded Retainer (5), screw Threaded Retainer (5) over Pneumatic Device (1).
3. Lock Threaded Retainer (5) in place with Retainer Lock Spring (10).
4. Insert rear Retainer Ring (3) over Threaded Retainer (5) .
5. Slide 2", 3", or 4" Adapter (2) over Threaded Retainer (5) and lock in place with forward Retainer Ring (3) .

Disassembly of Safety Hammer is roughly the reverse of the above steps.

REPLACEMENT OF IMPACT TOOL

(See Figure 4b)

1. Remove Retainer Lock Spring (10).
2. Unscrew Threaded Retainer (5) from Pneumatic Device (1).
3. Remove the following parts from inside the Threaded Retainer (5) as shown in Figure 4b.
 - Worn Impact Tool (4)
 - Split Upper Buffer Washer (9)
 - Solid Rubber Buffer (8)
 - Split Lower Buffer Washer (7) with Ring (6)
4. Insert the following parts inside the Threaded Retainer (5) as shown in Figure 4b.
 - Split Lower Buffer Washer (7) with Ring (6)
 - Solid Rubber Buffer (8)

- Split Upper Buffer Washer (9)
 - Insert new Impact Tool (4)
5. With parts ((4), (6) - (9)) positioned inside Threaded Retainer (5), screw Threaded Retainer (5) over Pneumatic Device (1).
 6. Lock Threaded Retainer (5) in place with Retainer Lock Spring (10).

OPERATION

OVERVIEW

Assembly of unions with Safety Hammer should be done by persons qualified to do so either by training or reading and understanding the manual. Training is available on a regular basis from Weir SPM. Contact Weir SPM at 1-800-342-7458 for more information.

Prior to use, all Safety Hammer and hammer union components should be inspected for general damage. Any damaged part should be immediately withdrawn from use.

Failure to follow Weir SPM suggestions for equipment, methodology, and verification may result in improper installation of Safety Hammer and hammer union components, possibly resulting in injury and even death.

INSTALLATION EQUIPMENT, ACCESSORIES AND SPECIFICATIONS

Minimum Air Requirements - In order for the Safety Hammer to function as intended, minimum air requirements must be met. Weir SPM recommends:

- 29 SCFM per Safety Hammer
- Air pressure of 90 psi at the Safety Hammer
- 1/2" air supply hose size with 3/8" NPT male thread plug and 1/2" hose barb coupler.

Failure to supply these minimum requirements will increase assembly time and possibly reduce life of hammer tool due to starvation. In order to minimize pressure drop from the compressor, it is recommended that the minimum air supply hose size be observed.

UNION ASSEMBLY:

The below instructions detail the suggested steps on how to properly assemble a hammer union.

1. Unions should be properly cleaned and lightly oiled before using. Union seals should be visually examined prior to makeup and replaced if worn, torn, or cracked.
2. Hand tighten hammer union connection until wing nut ceases to rotate.
3. Slide Safety Hammer adapter over wing nut so that it bears against one of the three lugs. **Orient so that the impact tool striking the wing nut lug will tighten the connection.**
4. Apply a turning force to the gooseneck handle until the wing nut ceases to rotate.
5. Squeeze the trigger and apply a slight turning force to the gooseneck handle.
6. The hammer union connection is tight when the wing nut ceases to rotate. A noticeable change in impact sound normally accompanies this.

UNION DISASSEMBLY:

The below instructions detail the suggested steps on how to properly disassemble a union connection.

1. Slide Safety Hammer adapter over wing nut so that it bears against one of the three lugs. **Orient so that the impact tool striking the wing nut lug will loosen the connection.**
2. Squeeze the trigger and apply a slight turning force to the gooseneck handle.
3. The hammer union connection is loose when the wing nut can be turned by hand.
4. Complete removal of wing nut by hand.

Weir SPM has determined that the Safety Hammer, when used in accordance with these recommended practices, will produce adequate make-up and break-out power.

It is important to note that operating conditions will differ among service companies and their procedures. Type and technique of operations vary drastically around the world. Customers must evaluate their specific application and establish procedures and maintenance that guarantee that connections are properly assembled. Weir SPM is available to provide guidance, but the end-user of the equipment has ultimate say and responsibility on how it is applied.

USING THE SAFETY HAMMER



PARTS LIST

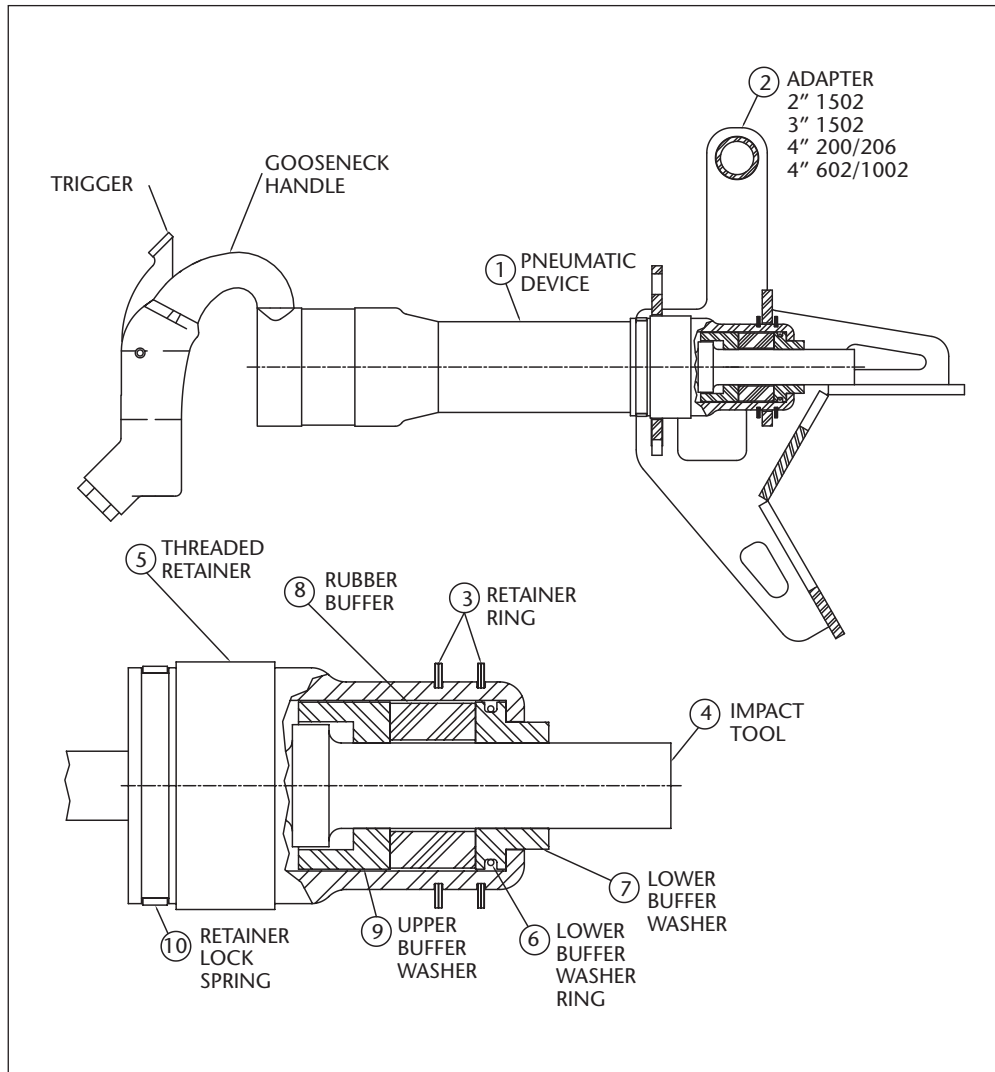

Figure 6. Safety Hammer Parts List

COMPLETE PARTS LIST

Parts List	Item										
	Figure 6	1*	2**	3	4	5	6	7	8	9	10
Description and Size	Safety Hammer Assembly	Pneumatic Device	Adapter	Retainer Ring	Impact Tool	Threaded Retainer	Lower Buffer Washer Ring	Lower Buffer Washer	Rubber Buffer	Upper Buffer Washer	Retainer Lock Spring
Safety Hammer 2" 1502	2A26689	2A26730	2P26690	P26733	2P26726	2P26728	P26768	P26769	P26770	P26771	P26772
Safety Hammer 3" 1502	2A26699	2A26730	2P26700	P26733	2P26726	2P26728	P26768	P26769	P26770	P26771	P26772
Safety Hammer 4" 200/206	2A26886	2A26730	2P26887	P26733	2P26726	2P26728	P26768	P26769	P26770	P26771	P26772
Safety Hammer 4" 602/1002	2A26709	2A26730	2P26710	P26733	2P26726	2P26728	P26768	P26769	P26770	P26771	P26772

* NOTE: Pneumatic Device (Item 1) includes items 4 (Qty 4) and 5-10 (Qty 1).

** NOTE: Adaptor (Item 2) includes item 3 (Qty 2).

TROUBLESHOOTING GUIDE

SYMPTOM	PROBLEM	SOLUTION
Sluggish Operation	Dirt or oil gum accumulation on pneumatic device internal parts.	Pour about 3 cc of a clean, suitable, cleaning solution into the air inlet and operate for 4 seconds. After flushing, pour about 3 cc of oil into the air inlet and operate the tool for 5 seconds to coat the internal parts with oil.
Loss of power	Worn pneumatic device.	Contact Weir SPM Service Centers or Weir SPM Fort Worth regarding pneumatic device.
Low efficiency	Worn pneumatic device and/or impact tool.	Replace impact tool. If problem continues contact Weir SPM Service Centers or Weir SPM Fort Worth regarding pneumatic device.
Excessive wear of impact tool.	Worn impact tool. Contact end of impact tool has mushroomed to the extent where it has lost its utility.	Replace impact tool. The impact tool is a consumable part. However, be sure to follow manual instructions on how to properly use the Safety Hammer. Excessive hammering will cause tool to wear faster.

NOTICE

**SAVE THESE INSTRUCTIONS.
DO NOT DESTROY.**

SAFETY INFORMATION



IMPORTANT SAFETY INFORMATION ENCLOSED. READ THIS OPERATING AND MAINTENANCE INSTRUCTIONS MANUAL BEFORE OPERATING PRODUCT.

IT IS THE RESPONSIBILITY OF THE EMPLOYER TO PLACE THE INFORMATION IN THIS MANUAL INTO THE HANDS OF THE OPERATOR. FAILURE TO READ, UNDERSTAND AND FOLLOW THE OPERATING AND MAINTENANCE INSTRUCTIONS MANUAL COULD RESULT IN SEVERE PERSONAL INJURY OR DEATH.

Weir SPM

7601 Wyatt Drive
Fort Worth
TX 76108
USA

Tel: (817) 246 2461
Fax (817) 246 6324

www.weiroilandgas.com

