

Manifold Trailer Retrofit - Safety Iron® Components

Weir SPM's Safety Iron® "hybrid" integral connections have successfully been retrofitted into customers' existing manifold trailers as a solution to competitors' components cracking. Using mixed branches and crossovers, the integrals and other Safety Iron® components such as valves or swivels, can be conveniently installed in existing trailer high-pressure flow lines for superior performance and longer life. The "hybrid" components provide an upgrade to existing assets as a temporary solution, though the ideal alternative is to replace the entire hammer union high-pressure manifold with a complete Safety Iron® system.



Background:

Customers report to Weir SPM that they witness cracks in traditional hammer union connection components utilized in the high-pressure lines on manifold trailers manufactured by various competitors. These cracks can be associated with the hard mounting styles of the competitors' trailers, and the hammer union style connections being susceptible to fatigue fractures due to side loading and vibration.

Solution:

Customers are seeking more effective and longer lasting equipment in order to cut costs and extend the operating life of existing assets. In response, Weir SPM has seen great success in offering "hybrid" Safety Iron® integral connections (tees or laterals) that utilize mixed-style branches to retrofit into existing trailers. These hybrid components have shown to be more resistant to the damaging effects of vibration due to the robust Safety Iron® design which utilizes greater wall thickness in key areas, and more contact surface area (see drawing below).

Weir SPM is now promoting its Engineering expertise to help customers determine how the "hybrid" integral connections and/or a complete Safety Iron® high-pressure manifold replacement can benefit their existing inventory.

Success Story:

Safety Iron® retrofit kits have been utilized by several customers. One leading pressure pumper, in particular, retrofitted several of their existing manifold trailers with the Weir SPM "hybrid" integral components on trailers originally manufactured by a Weir SPM competitor. The customer had complained of the competitor's integrals failing within 20 - 200 hrs of installation due to vibration during high pressure pumping, and was seeking a better alternative that would eliminate replacement costs.

Weir SPM's "hybrid" integrals were conveniently installed into the existing flow lines on the trailers. The new integrals displayed +1,000 hour life with no issues.

The durable connection of Weir SPM's Safety Iron® is ideal for semi-permanent applications such as manifold trailers or pump bridles. Contact your nearest Weir SPM representative to find out how Safety Iron® can benefit you.

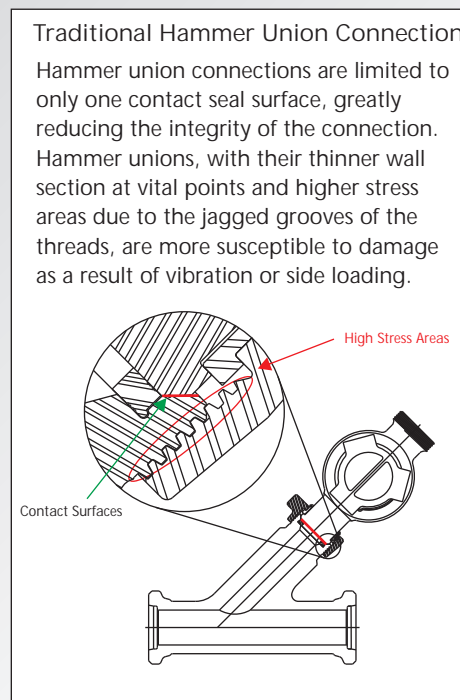
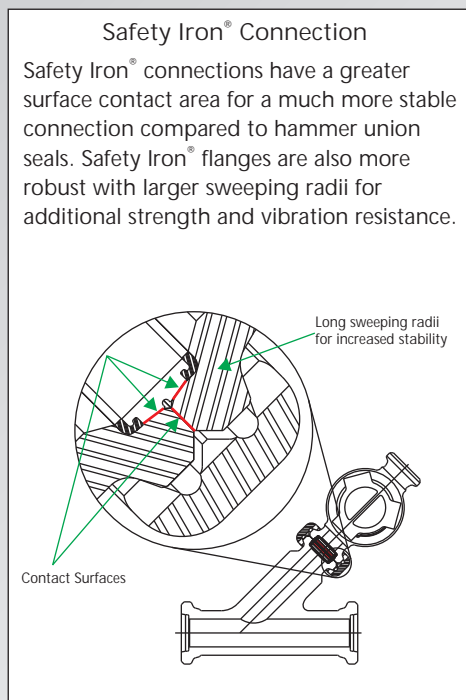

Weir SPM

7601 Wyatt Drive
Fort Worth
TX 76108
USA

Tel: (817) 246 2461
Fax (817) 246 6324

www.weiroilandgas.com

