



JUNE 01, 2009

Competitor Manifold Trailer - Safety Iron® Retrofit

Weir SPM's Safety Iron® "hybrid" integral connections have successfully been retrofitted into customers' existing manifold trailers as a solution to competitors' components cracking.

Background

Recently, customers reported to Weir SPM that they began witnessing cracks in traditional hammer union connection components utilized in the high-pressure lines on manifold trailers manufactured by our competitors. These cracks can be associated with the hard mounting styles of the competitor's trailers, and the hammer union style connections that are more susceptible to fatigue fractures due to side loading and vibration.

Solution

Due to the current economic climate, customers have been hesitant to invest in new trailers or complete changeover maintenance from hammer union units to Safety Iron®. Yet, these customers are seeking more effective and longer lasting assets in order to cut costs. In response, Weir SPM has seen great success in offering "hybrid" Safety Iron® integral connections (tees or laterals) that utilize mixed-style branches (see Figure 1) to retrofit into existing trailers. These hybrid components have shown to be more resistant

to the damaging effects of vibration due to the robust Safety Iron® design which utilizes greater wall thickness in key areas, and more contact surface area (see Figure 2 below).

To date, retrofit "kits" have been sold to multiple customers. Initial reports from these customers state that after continued use, no further problems have been witnessed with the Safety Iron® integral connections. Weir SPM is now promoting its Engineering expertise to help customers determine how the "hybrid" integral connections can benefit their existing inventory.

The Weir Way

[INNOVATIVE ACTION]

[COLLABORATIVE MINDSET]

[GLOBAL CAPABILITY]

Weir SPM: Product Bulletin

Weir Oil & Gas
7601 Wyatt Drive
Fort Worth, Texas 76108
USA

817 246 2461 tel
817 246 6324 fax
www.weiroilandgas.com

Excellent
Oil & Gas
Solutions

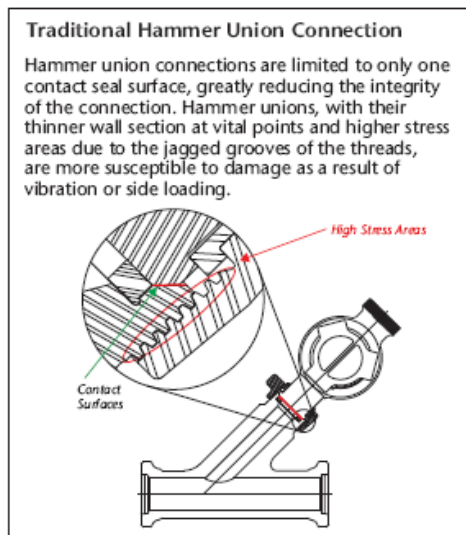
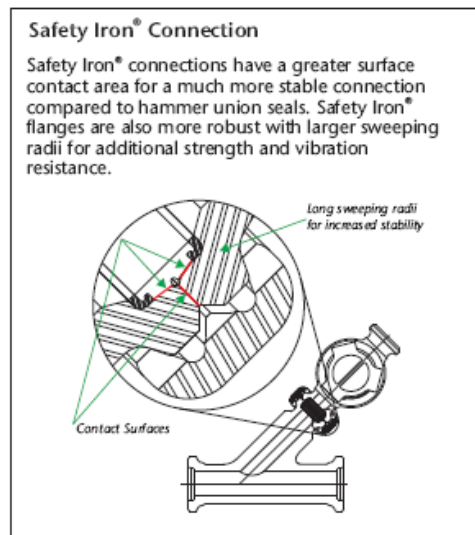

FIGURE 1



Note: Not shown, 3" 15K Tee branch leads to Plug Valves (3" 15K SI x 3" 1502 Hammer Union).

FIGURE 2



The Weir Way
[INNOVATIVE ACTION]
[COLLABORATIVE MINDSET]
[GLOBAL CAPABILITY]