



Pump Monitoring Device (PMD)

Protect your well service pumps with instant real time information during operation.

Weir SPM's PMD was developed to allow users to continually monitor the status of their pumps in real time. Information on the pump's current operation is constantly being fed and displayed to the customer in an easy to view format.

The PMD gives the user the opportunity to make the necessary changes during operation to minimize or prevent costly damage to pumping equipment, and increase the longevity of their pumps.



PMD Sensor Layout

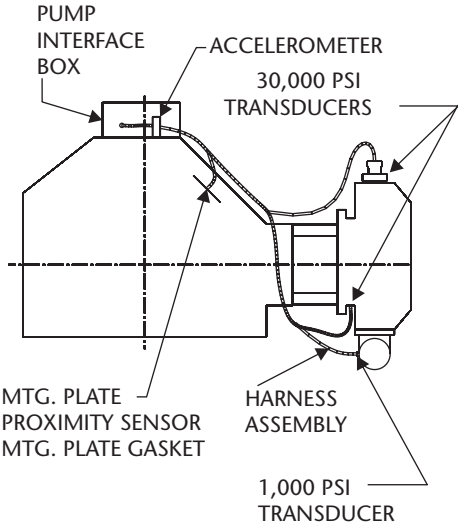

Now Available... REAL TIME DATA for unmatched pump troubleshooting capabilities.

The PMD System is easily installed and can transmit data directly to the data van on site. The system's software is both user-friendly and exceptionally informative. Detailed information is available for each equipped pump in operation, with alarms set up to warn users if an unfavorable condition occurs. Weir SPM's PMD is the ultimate tool to protect your pumps and operate at maximum efficiency.

Consisting of a Pump Interface Box and various sensors on the pump, and a Data Interface Box with CPU located in the data van, the PMD will deliver information to monitors installed in the data van in real time. The PMD software will display vital information to the user and offer troubleshooting suggestions to allow the user to quickly respond to any issue with their equipment.

Information Available:

- Pump Speed (RPM)
- Discharge Valve Status
- Suction Valve Status
- Discharge Pressure
- Charge Pressure
- Shock Loading
- Cavitation
- Rod Load

Three status color indicators exist:
Green - Acceptable Status
Yellow - Caution Status Detected
Blinking Red - Unacceptable Condition

Available in 1, 5 or 10 pump setups.

PMD allows the user to monitor the condition of specific valves.

	RPM	Discharge Pressure		Charge Pressure	Shock Loading	Cavitation	Rod Load
		Discharge Valves	Suction Valves				
Pump 01	84 RPM	5297 PSI		39 PSI	0.8 G	OK	54%
Pump 02		1 2 3 4 5	1 2 3 4 5				
Pump 03							
Pump 04							
Pump 05							

EVENT MONITOR DISPLAY

15:27:59 09/05/06: Pump Number 1 Charge Pressure Too Low event start

Time: 15:28:05

The PMD informs users on the current status of their pumps through status indicator "alarms". A wealth of information is available to the user in an accurate and easy to read format that is unmatched by any other system available to the market.

Start Up Data

By clicking the "Current Status" button an event monitor will display the current real-time operating conditions of the pump.

Data is automatically retained during unacceptable conditions, as well as a message being shown with recommended corrective actions for the issue.

Weir SPM

7601 Wyatt Drive
Fort Worth
TX 76108
USA

Tel: (817) 246 2461
Fax (817) 246 6324

www.weiroilandgas.com

