



Grooveless Fluid End

Weir SPM Offers a Grooveless Fluid End Designed to Provide Extended Product Life in Harsh Pumping Environments Through the Utilization of Greater Material in Critical Points.

Numerous models of Weir SPM well service pumps have traditionally featured a fluid end utilizing a "wing style" valve stop which is locked in place through grooves machined into the suction bore. This "wing style" fluid end has performed very well for many years. However, through Weir SPM performance studies, it was determined that during harsh environment operations, the "wing style" fluid end was susceptible to wash occurring in the grooves machined in the suction bore. Honoring a commitment to continual improvement practices across all of its product lines, Weir SPM designed a new style of fluid cylinder that eliminates the grooves machined in the suction bore. This new design is intended to greatly reduce the opportunity for wash to occur, ultimately extending product life without sacrificing performance.

The Grooveless Fluid End utilizes a new style of valve stop that locks under a ridge in the top of the suction bore and into the suction cover. The valve stop is easily installed with the use of a valve stop installation tool. The Grooveless Fluid End style is recommended for use in all high-horsepower pump models, particularly pumps running in harsh pumping environments, such as tight shale fracturing operations.

Realizing that some customers may prefer to continue utilizing the "wing style" fluid cylinder, Weir SPM will continue offering this model as well as its expendable components parts, in addition to the Grooveless Fluid End design.

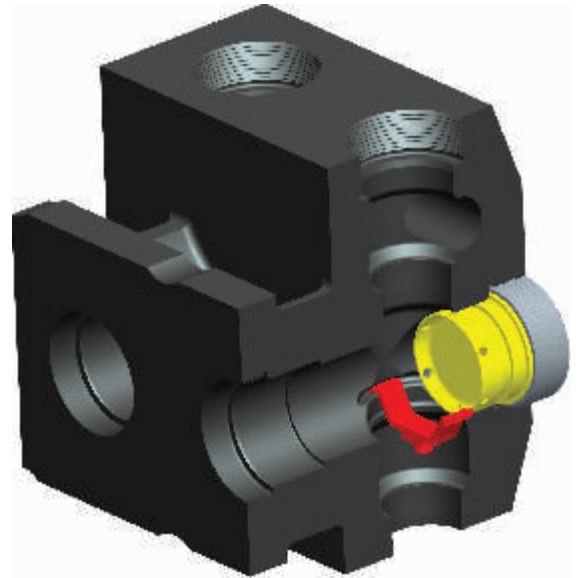

The traditional "**wing style**" fluid end uses a grooved suction bore to lock the valve stop in place. This groove reduces material in key locations possibly leading to cracks in the cylinder during the mature phase of its life cycle.

Benefits of the Grooveless Fluid End Design:

- Reduces the risk of washout problems through the elimination of the suction bore groove.
- Prevention of stress cracks which have a greater tendency to start in the grooves.
- Allows for increased pumping durations, pressures and flow rates.
- Extended product life in harsh pumping environment.

Product Availability:

Plunger Size	Pump Model
4 1/2" - 5"	TWS 2250 & QWS 2500 (Classic & SD)
5 1/2" - 6"	TWS 2250 & QWS 2500 (Classic & SD)
6 1/2" - 6 3/4"	TWS 2250 & QWS 2500 (Classic & SD)

Note: Other pump models are available. Please contact Weir SPM Sales for more details.

Weir SPM

7601 Wyatt Drive
Fort Worth
TX 76108
USA

Tel: (817) 246 2461
Fax (817) 246 6324

www.weiroilandgas.com

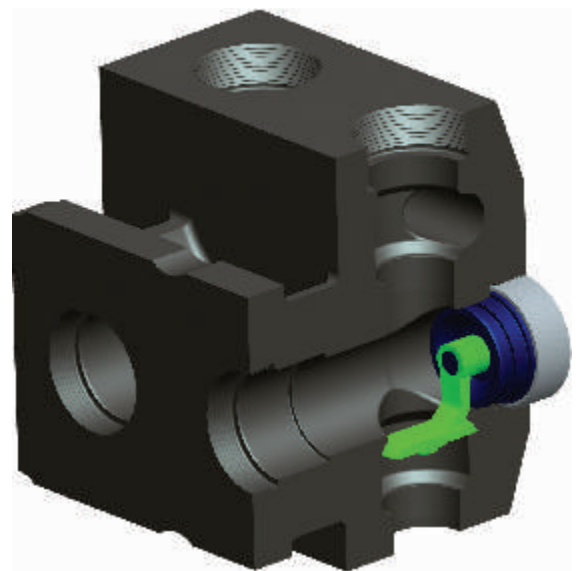

Weir SPM's new **Grooveless Fluid End** eliminates the groove in the fluid cylinder by replacing the old "wing style" valve stop. The new valve stop design locks under a ridge in the fluid cylinder bore and is held in place through a stem on the suction cover.