



Excellent
Oil & Gas
Solutions



Emergency Back Pressure Relief Valve

Operating and Maintenance Instructions

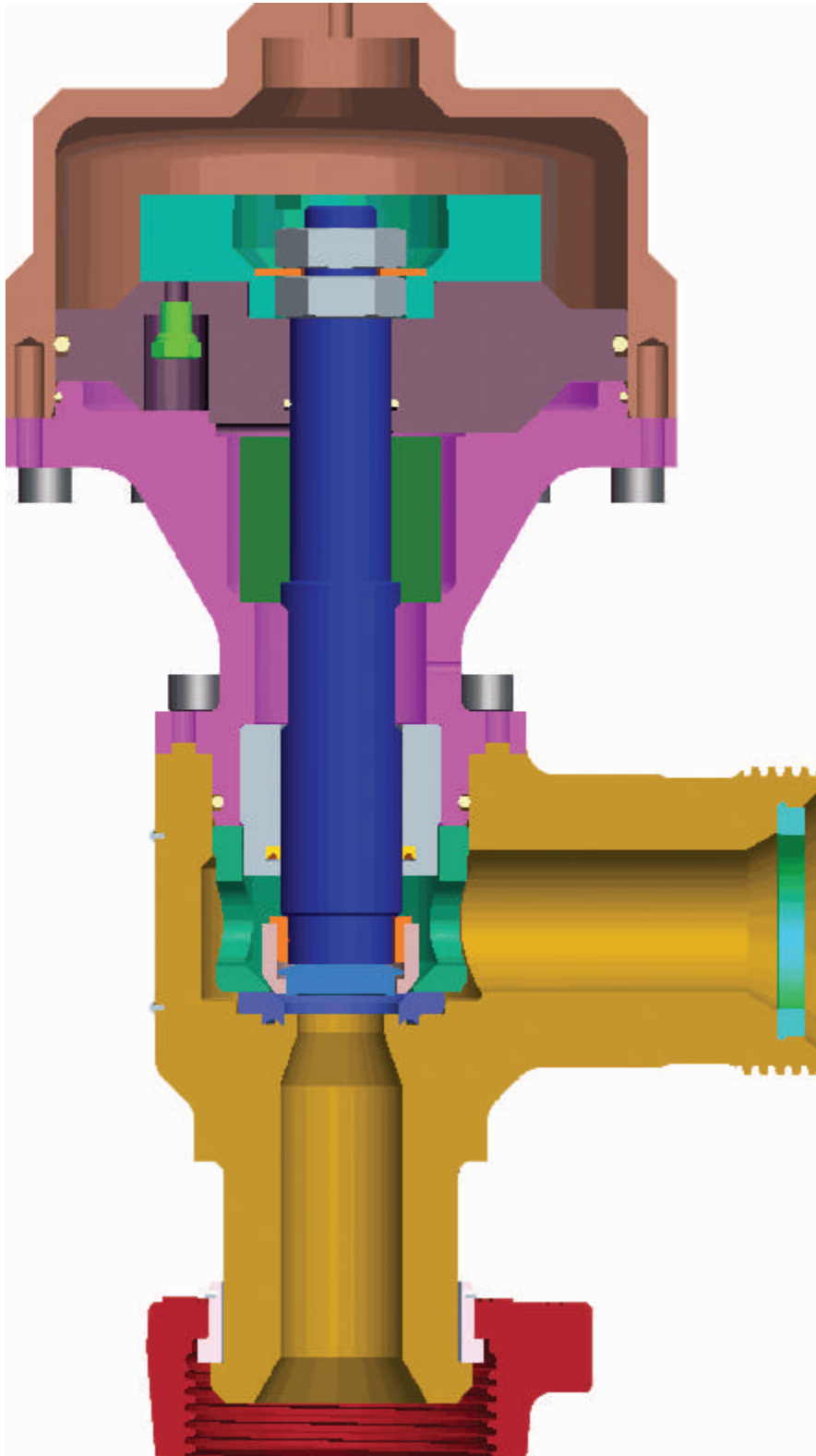

SAFETY INFORMATION



IMPORTANT SAFETY INFORMATION ENCLOSED. READ THIS OPERATING AND MAINTENANCE INSTRUCTIONS MANUAL BEFORE OPERATING PRODUCT.

IT IS THE RESPONSIBILITY OF THE EMPLOYER TO PLACE THE INFORMATION IN THIS MANUAL INTO THE HANDS OF THE OPERATOR. FAILURE TO READ, UNDERSTAND AND FOLLOW THE OPERATING AND MAINTENANCE INSTRUCTIONS MANUAL COULD RESULT IN SEVERE PERSONAL INJURY OR DEATH.

Contents

Product Description.....	3
Pressure/Temperature Ratings.....	3
End Connections.....	3
Description of Operation.....	3
Installation.....	3
Maintenance.....	4
Service.....	5
Disassembly.....	5
Replacement and Assembly.....	8
Setting and Adjusting Pressure.....	8
Vessel Test Procedures.....	9
Trouble Shooting Guide.....	12
Parts and Seals Kit Listing.....	13
Drawing of 3" Valve - 15,000 NSCWP.....	14
Drawing of 3" 20K Valve - 20,000 NSCWP.....	15
Drawing of 4" Valve - 602/1002.....	16
Drawing of 4" Valve - 1502 MxF - 15,000 NSCWP.....	17
Drawing of 4" 10K Safety Iron Valve - 10,000 NSCWP..	18
Drawing of 4" 15K Big Iron Valve - 15,000 NSCWP.....	19

I. Product Description:

Weir SPM's Emergency Back Pressure Relief Valve provides over-pressure protection for reciprocating pumps, treating lines, pressure vessels, and other equipment operating under high-pressure, high-flow conditions. Compact and simple to operate, the valve is direct acting, relying on the system's hydraulic pressure to overcome a preset nitrogen gas force to relieve. It is externally adjustable from zero pressure to maximum setting.

Unlike Shear Relief Valves, which use common nails to trigger the release, the Weir SPM valve will reseat once the system pressure reduces. And unlike many "High-Lift" Valves, which require a substantial drop in pressure before they will reseat, the Weir SPM valve exhibits little blow down and will reseat at or near the "cracking pressure".

Manufactured to Weir SPM's stringent Quality Assurance System, all pressure bearing components are made from high quality material. The forged body features an integral wing union male inlet or Safety Iron™ type connections, suitable for the pressure rating of the component.

The low-pressure outlet is available with an integral wing union female or Safety Iron™ connection. Conforming to conditions of design and performance in API RP520, the Weir SPM Emergency Back Pressure Relief Valve is intended for liquid service. It is not intended for elevated temperatures nor as a safety device in case of fire.

Available in 3" or 4", this valve offers pressure ranges from 1,000 - 20,000 psi. The valve is best suited for over pressure protection in a "slick water" medium. However, due to its large bore, it should work well in drilling mud applications also.

II. Pressure/Temperature Ratings:

The Weir SPM 3" or 4" Emergency Back Pressure Relief Valve is available in the following configurations at this time.

Fluid Side Ratings:

INLET	(LOW PRESS) DISCHARGE	PRESSURE RANGE (PSI)	INT. END NSCWP (PSI)	SERVICE	SEALS TEMP. RANGE
3" - 1502M	3" - 1502F	1000 - 15000	15000	Standard	-30°C - 110C
3" - 2002M	3" - 2002M	1000 - 20000	20000	Standard	-30°C - 110C
4" - 1002M	4" - 1002M	1000 - 10000	10000	Standard	-30°C - 110C
4" - 1502M	4" - 1502M	1000 - 15000	15000	Standard	-30°C - 110C

Gas Side Specifications:

Low Pressure Working Range: 0 to 800 psi
 Recommended Nitrogen Bottle: 2,000 psi
 Recommended Rupture Disc: 2,250 psi

Bottle or source gas pressure should be twice maximum low pressure working range.

Operating Temperature: -22°F to 120°F
 (-30°C to 49°C)

III. End Connections:

Weir SPM's 3" or 4" Emergency Back Pressure Relief Valve is available with Weir SPM Wing Union or Safety Iron™ Connections. The nameplate will indicate the cold working pressure allowable for each assembly.

Wing union connections on the relief valve are interchangeable with other union connections of the same size and figure (pressure rating). Caution must be taken to avoid mixing different ratings of wing connections. There are various sizes and figures that are capable of making marginal connections. Safety Iron™ connections are universal requiring no male or female as the wing union does. Failure to observe good judgement may lead to failure of components and danger to life and limb. Always verify working pressure ratings of each connection before use.

This device is intended to discharge to atmospheric pressure when it relieves. It should not be subjected to any significant backpressure. The choice of discharge connections is offered as a convenience for the user and does not imply high-pressure capability.

Observe all instructions, cautions and warnings as noted in this brochure. Failure to do so can lead to equipment damage, personal injury or loss of life.

⚠ WARNING: NEVER BLOCK DISCHARGE PORT!

IV. Description of Operation

The back pressure relief valve operation is a simple balance between the nitrogen (or suitable gas) acting on the piston and the inlet liquid pressure acting on the rod and wear sleeve. The equation is **Pressure times Area equals Force (PxA=F)**. The ratio of areas is approximately: 25.0:1 for the 15,000 psi rated valve

This means that nitrogen pressure of 100 psi can counter an inlet line pressure of 2500 psi for the 15,000 psi rated Emergency Back Pressure Relief Valve. Variations in this ratio in practice are due to friction of seals and will be discussed in section **VIII. Setting and Adjusting Pressure.**

V. Installation:

The Weir SPM Emergency Back Pressure Relief Valve should be installed in a branch on the high-pressure pump line (Fig. 1). To avoid stability problems, the valve should not be mounted directly at the pump discharge, but rather somewhat removed from the pump due to the fluctuating discharge signature of the pump. Preferably, the valve should be mounted in the vertical position as shown, to reduce the tendency for contaminants and particulates in the fluid to collect at the throat of the main seal. However, any position is acceptable within approximately 30 degree declination (angle from vertical).

The gas regulator and gas back pressure relief valve should be installed as close to the relief valve as possible. The nitrogen filled high-pressure cylinder must be secured to either a skid or trailer or by staking it to the ground.

Any type of liquid may be unloaded through the valve. The valve will tolerate clean liquids better than others. And lighter liquids will flow greater rates than heavier liquids. Particulates, abrasives and contaminants will not preclude the valve from opening at the appropriate set pressure. However, abrasive materials will cause some wear between the wear sleeve, nozzle, and main seal. While these components feature wear resistant surfaces, their life will be reduced as the abrasives increase in the fluid.

CAUTION

It is important for the user to consider the consequences of a valve that does not fully reseat after it has relieved. In the event that this might present a danger to personnel or equipment, Weir SPM highly recommends that an isolator valve be placed between the pressure line and the Relief Valve.

With the device installed, as shown in (Fig. 1), any time the pressure exceeds the set pressure at the Emergency Back Pressure Relief Valve, the fluid will pass through the valve and out the discharge.

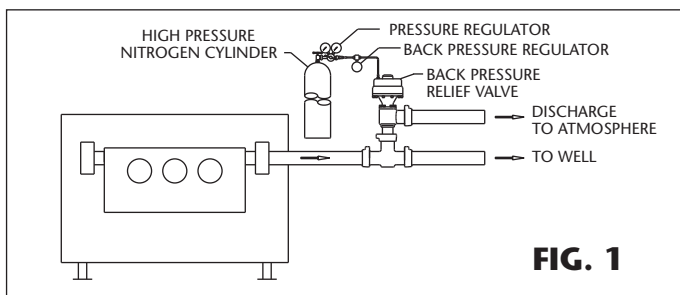

FIG. 1

At low flow rates, the valve will discharge fluid at approximately the set pressure (Fig. 2). At higher flow rates, the valve will discharge fluid at levels above the set pressure. API 520 defines the valve flow capacity as the rate that can be relieved at an over pressure of 25%. When the fluid pressure falls to the set pressure level or below, the valve will reseat and reseat.

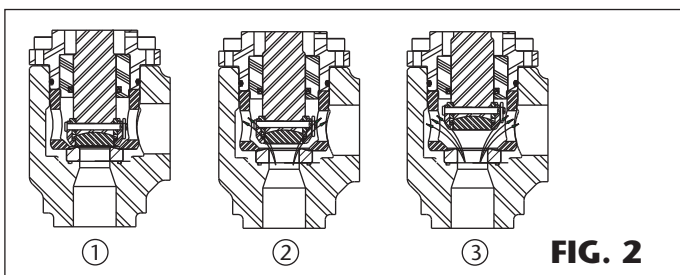

FIG. 2

- ① Fluid pressure below set pressure-rod and valve gate seated and resealed.
- ② Fluid pressure slightly above set pressure-rod and valve gate slightly off nozzle.
- ③ Fluid pressure substantially above set pressure-rod and valve gate off nozzle.

CAUTION

Weir SPM's 3" or 4" standard service Emergency Back Pressure Relief Valve is not intended for use in the sour gas environment. ⚠️ WARNING: DO NOT USE FOR H2S SERVICE. Weir SPM does offer a separate series of H2S service back-pressure valves. Contact your Weir SPM representative for advice about sour gas service applications.

ALWAYS REMEMBER

1. ⚠️ **WARNING: DISASSEMBLY UNDER PRESSURE CAN CAUSE SERIOUS INJURY OR DEATH.**
2. Always use a new parts kit for reassembly.
3. Clean all components thoroughly prior to reassembly using protective clothing and safety glasses.
4. Check sealing surface area of valve gate and nozzle for pitting, erosion or other flaws. Failure in sealing can result if these areas are not smooth.
5. Use only Weir SPM relief valve parts on Weir SPM relief valves.
6. This device is intended to discharge to atmospheric pressure when it relieves. It should not be subjected to any significant back pressure.

VI. Maintenance:

General Inspection and Repair:

The Weir SPM 3" or 4" Emergency Back Pressure Relief Valve is a well designed, dependable component that should provide long term reliable performance for the user. Like any device, however, it requires routine inspection and servicing to guarantee that it is fully functional.

The valve is intended to be used as an emergency pressure relief device only, and should not be subjected to continuous fluid flow except in emergency situations. If the valve is subjected to extended flow or abrasive fluids, the valve may not reseat completely once the pressure is relieved. If complete fluid shut-off is desired, a shut-off valve (such as Weir SPM's plug valve) should be installed in series with the relief valve, which can be closed once the over-pressure is relieved.

Weir SPM recommends that the valve be serviced on a **weekly** basis. O-rings and the mating seal surfaces can be inspected at that time and replaced as required. There are sealing surfaces on this device that require maintenance. For the valve to operate properly and safely, these items must be kept in good condition. Inspection and servicing should be conducted in accordance with a recognized maintenance program. The more severe the usage, the more often the maintenance.

Any time the valve is sequenced in operation as a result of overpressure (other than routine calibration with water prior to pumping operations), it must undergo a teardown and comprehensive inspection. **This should be done immediately following the completion of the current job.** Not properly servicing the valve once it has discharged frac media (including frac sand) is dangerous practice and increases the risk of leakage during the next operation. Disassembly, Repairs, and Reassembly should be done in accordance with service manual instructions.

In order to determine the N2 gas line pressure, the valve is equipped with a corrosion resistant bourdon tube gauge with a pressure rating of 0 to 600 psi. This range is adequate to allow the valve to reach maximum operational working pressure, and yet still allow precise adjustments in line pressure. However, if the relief valve is only operated at release pressures below 6000 psi, then the pressure gauge could be replaced with a 0 - 300 psi gauge. This would increase the accuracy at which the N2 gas line pressure could be adjusted. The primary consideration is not to operate the pressure gauge beyond 75% of its rated capacity for any extended period of time. If additional information is needed, please contact the Weir SPM Engineering department.

VII. Service:

TOOLS REQUIRED

1. Vise
2. 1/2" Hex Socket Wrench & 1/4" Hex Socket Wrench
3. Screwdriver
4. 2 lb. Hammer
5. Special Torque Tool (see Fig. 6)
6. Ø 1/2" BAR x 12" LG (Aluminum or Brass)
7. 600 Grit Sandpaper
8. Anti-seize Lubrication
9. Hand and Eye Protection
10. (2) 1/2 - 13 UNC x 1 1/2 LG bolt (for cylinder extraction)

DISASSEMBLY: (Fig. 3 & 4)

⚠ WARNING: MAKE SURE THAT THERE IS NO PRESSURE ON THE VALVE

1. If the nitrogen cylinder is attached, close the high-pressure cylinder valve (2). Then bleed down and remove the nitrogen line (14) from the back-pressure valve (1) (Fig. 3).
2. Secure the valve in a horizontal position by clamping the valve body (3) in a vise (Fig. 4).
3. Remove the eight lower and ten upper 5/8" socket screws (30) from the flange (1). Separate the cylinder (5) from the flange (1). If piston extraction is difficult after jackscrews are fully extended replace with 1/2 -13 UNC x 1 1/2 LG or longer bolts for easier disassembly. Separate the flange (1) from the body (3) by using jackscrews. Remove the entire bonnet assembly from the body.
4. Remove the cotter pin (13) from the clevis pin (29). Remove the clevis pin (29) from the cylinder rod (4). The valve gate (23), wave spring (14), spring retainer (9), and bushing (10) can now be removed from the cylinder rod (4). Remove the piston (8) with the cylinder rod from the flange assembly (1).
5. Hold the cylinder rod (4) by the flat at its mid length. Exercise care not to damage the rod's other surfaces. Remove the hex jam nut (22) and washer (33) from the cylinder rod (4). The bumper (32) can now be removed. Remove the jam nut (22). Then the piston (8) and sleeve (21) can be removed.
6. Remove the spider (11) from the valve body (3). Remove the nozzle (6) along with the seat (12) from the body.
7. Gently remove the seal (28) from the valve body (3).

Inspecting Components: (Fig. 4)

1.) Body: (3)

Visually inspect the o-ring groove area beneath the nozzle (6). This is a critical area. If the groove shows indications of damage from erosion or corrosion, the body should be replaced. It is not repairable.

Visually inspect the fluid discharge surface for erosion or corrosion. Some wear in this area is expected. Any damage to this surface that extends deeper than .10" renders the part unusable and it should be replaced.

Visually inspect nylon guide bushing on flange assy (1) seal surface for erosion or corrosion. Damage to this area will

allow fluid to leak past the flange during the relieving function. If this surface shows signs of damage, the body should be replaced.

2.) Cylinder: (5)

Visually inspect the inside surface of the cylinder for wear or damage. Damage to this surface renders this component unusable and should be replaced.

3.) Piston: (8)

Visually inspect the piston seal areas for damage or wear. If damage or wear is evident, the part should be replaced.

4.) Flange: (1)

Inspect the seal (26) pocket in the nylon sleeve at the bottom. Inspect seal (19) and (25) pockets for wear. The sleeve and seal pockets should be in good condition. If not the flange should be replaced.

5.) Spider: (11)

Visually inspect the fluid discharge areas for erosion and corrosion. Some wear in these areas is expected. Any damage in these areas that extends deeper than .06" renders the parts unusable and they should be replaced.

6.) Valve Gate (23) and Nozzle (6):

The gate and nozzle are considered expendable items and spares should be kept on hand at all times. The life of these parts is dependent on the type and length of service to which they are exposed.

Visually inspect the gate and nozzle for indications of wear and of pitting, erosion or corrosion damage. These are critical components in the function of the valve. Any indications of deterioration more than .01" deep should be cause to replace these items. Deterioration of the sealing surfaces less than .01" deep should be removed by polishing with 600 grit sandpaper. Keep flatness of surface when polishing. Total depth of polishing should not be more than .015" for each sealing surface. Look for contaminants that, while not damaging to the gate and nozzle, will keep the parts from sealing. Remove any foreign material found.

7.) All Seals: (15) (19) (24) (25) (26) (27) (28)

All elastomer seals should be replaced regardless of condition.

**See drawing 2L23886 (page 13)
for Seal and Part Kits.**

**See all assembly drawings for
3" and 4" configuration for
parts and seal part numbers
(pages 14 through 19).**

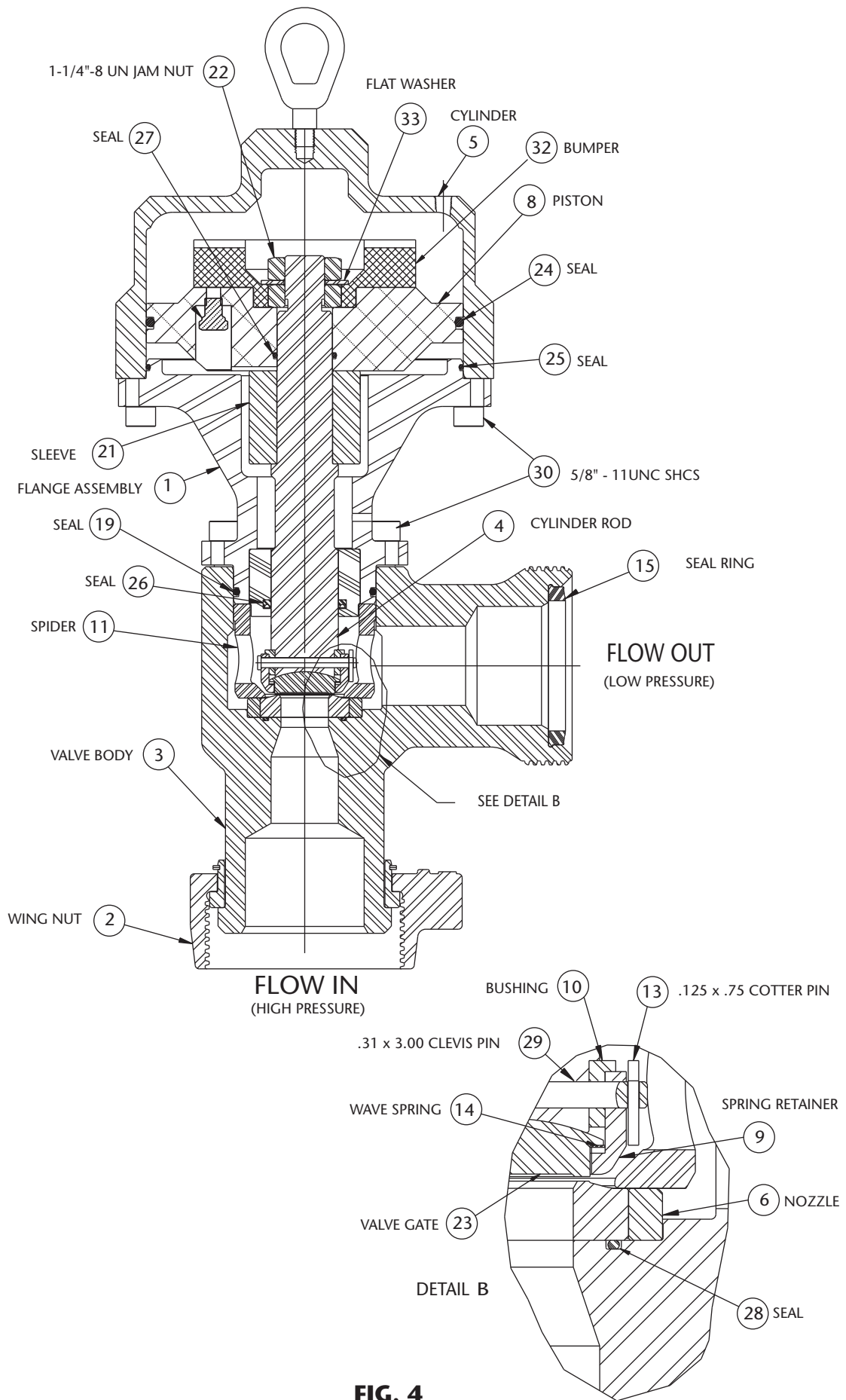

FIG. 4

REPLACEMENT AND ASSEMBLY

- See **ALWAYS REMEMBER** Section before assembly.
 - The reassembly of the valve is in approximate reverse order to the disassembly process. Ref (Fig. 4).
 - Lightly lubricate all surfaces prior to assembly.
1. Install seal (28) into valve body. Replace nozzle (6) and fit over seal (28). **CAUTION:** If seal (28) is difficult to seat, push into place with seat and tap lightly. Remove seat to ensure seal is properly seated. Install the spider (11) into the valve body (3) and fit to the nozzle (6).
 2. Secure the cylinder rod (4) in a vertical position using the flats at its mid length.
 3. Install the sleeve (21) and the piston (8) with seals (27) and (24) onto cylinder rod (4). Secure the piston (8) with jam nut (22) using blue Loctite. Install bumper (32), washer (33) and hex jam nut (22) using blue Loctite.
 4. Install seals (25), (26) and (19) into the flange assembly (1). Uniformly apply a small amount of anti-seize compound on the inside friction surface of the nylon bushing of the flange assembly (1). Carefully insert the cylinder rod (4) with piston (8) into the flange assembly (1).
 5. Insert wave spring (14) into spring retainer (9) followed by new or polished valve gate (23). Install the bushing (10) into spring retainer (9). Assemble the spring retainer (9) and the cylinder rod (4) together by using the clevis pin (29). Secure the clevis pin (29) by cotter pin (13).
 6. Install the entire cylinder rod-flange package into the valve body (3). Tighten the eight 5/8" socket screws (30) that hold the flange assembly (1) to the body (3) using proper torque orientation to 110 ft-lb (lubricated).
 7. Install cylinder (5) onto flange (1) and tighten the ten 5/8" socket screws (30) using proper torque orientation to 110 ft-lb (lubricated).
 8. Tighten the connector (13) (See Fig. 3) into the cylinder (5) with thread sealing compound.
 9. Using shop air, connector (13) (See Fig. 3), and vent hole on the valve assembly (1), stroke the piston (8) in and out to assure that it moves freely.
 10. The valve is now ready for pressure testing as discussed in **Section VIII, Pressure Testing**.

Observe all instructions, cautions and warnings as noted in this manual. Failure to do so can lead to equipment damage, personal injury or loss of life.

VIII. Setting and Adjusting Pressure:

The Emergency Back Pressure Relief Valve is direct acting. The pressure set on the nitrogen regulator is directly related to the relief pressure. The higher the nitrogen pressure, the higher the relief set point. Use the following procedure to obtain the correct set point. A few attempts at working pressure may be required to confirm the set point (Fig. 3). Clean dry air at a minimum of 1350 psi (6000 psi max) may also be used.

CAUTION

Bleed off all air from the fluid system. Trapped air will become energized and may cause injury to personnel when the valve relieves.

1. Screw the pressure regulator (8) adjustment screw all the way out (Counter Clockwise) to open.

CAUTION

When the handle hits its stop, the top of the regulator may start to unscrew. Do not unscrew the regulator top any further. **WARNING: FAILURE TO COMPLY MAY CAUSE INJURY TO PERSONNEL WHEN PRESSURE IS APPLIED TO THE VALVE.**

2. Open the valve (15) on the nitrogen bottle or from the air source. The inlet gauge (6) on the regulator (8) should indicate the pressure in the nitrogen bottle.
3. Tighten the backpressure regulator (9) adjustment screw fully (Clockwise).
4. Turn the adjustment screw on the regulator (8) until the gas line pressure reaches a nominal set point. Use the chart in Figure 5 to find gas pressure versus "set" pressure.

NOTE

Always set the pressure in the Rising Direction. If you pass a set point drop the pressure to about 50 psi below the set point and re-approach the set point.

5. Test the working pressure by slowly raising the line (liquid) pressure until the valve begins to relieve. The treating line pressure should stabilize and stop rising once this happens.
6. Reduce the line pressure until the valve gate (23) is fully seated on the nozzle (6) (See Fig. 4).
7. The relationship between gas pressure and line (liquid) pressure is defined by Figure 5. These values are from actual tests and should be accurate. However, if the predicted gas pressure does not produce the desired set pressure, you may have to adjust the regulator (8) up or down.

Some of the factors affecting performance include temperature, and gas used (air vs nitrogen).

8. Reset the nitrogen pressure to the new set point. Test the line again until the valve relieves.
9. With pressure on the back pressure relief valve, back the adjustment screw of the backpressure regulator (9) (Fig. 3) out (Counter Clockwise) until the backpressure regulator exhausts gas.
10. Then slowly turn the adjustment screw in (Clockwise) until the backpressure regulator (9) just stops exhausting gas.

NOTE

Once the relief valve is adjusted to the correct set point it is normal for the gas pressure to rise as fluid in the discharge line (to well) (Fig. 1) approaches the set pressure. The backpressure regulator, will vent gas to compensate this increase in gas pressure.

VIII. Setting and Adjusting Pressure (continued):

NOTE: This chart does not apply to the 3" 2002/20K ERV valve. Contact Weir SPM Engineering for 3" 2002/20K Full Bore Emergency Unloading Valve Performance Data Values.

Line Set Pressure (PSI)	Required Nitrogen (or gas) Pressure (PSI)
350	0
500	14
1000	28
1500	41
2000	55
2500	69
3000	83
3500	97
4000	110
4500	124
5000	138
5500	152
6000	166
6500	179
7000	193
7500	207
8000	221
8500	234
9000	248
9500	262
10000	276
10500	290
11000	303
11500	317
12000	331
12500	345
13000	359
13500	372
14000	386
14500	400
15000	414

FIG. 5

IX. Vessel Test Procedures:

Prior to shipment, product testing procedure 4S12497 requires that each emergency valve pass a one time vessel test at 150% it's rated working pressure. Then, when conducting subsequent vessel tests on used or re-certified valves, limit the pressure to 100% of rated working pressure as required by 4S12497.

Emergency relief valves should always be vessel tested in accordance with product testing procedure 4S12497.

⚠ WARNING: A FULLY ASSEMBLED RELIEF VALVE SHOULD NEVER BE PRESSURE TESTED WITH THE OUTLET DISCHARGE PORT BLANKED OR BLOCKED OFF AS THIS WILL RESULT IN A CATASTROPHIC FAILURE. Below is excerpt from 4S12497 regarding the proper vessel testing procedure on used or recertified emergency relief valves:

Vessel Test Procedure for Used or Recertified Emergency Back Pressure Relief Valves

1. Assemble valve body with **required** blanking seat, spider, and dummy blanking cap for testing purposes only. (See Fig. 7 & 8 "Vessel Test Procedure" for seat, spider, and cap part numbers)
2. Attach valve to testing pump.
3. Fill with water and bleed-off all air from the system prior to testing.
4. Hydrostatically test by pressuring to 100% of product's designed working pressure.
5. Hold pressure for the duration to time specified in 4S12497 and check for leaks. Assembly is considered acceptable if there are no visual indications of leaks, and the pressure drop is within the allowable range specified in 4S12497, section 6.0 relief valve.
6. Reduce pressure to zero.

Recommendation: Purchase a spare spider designated for the sole purpose in testing relief ERV valves as to prevent damage to the "original spider" that was assembled in your N2 relief valve.

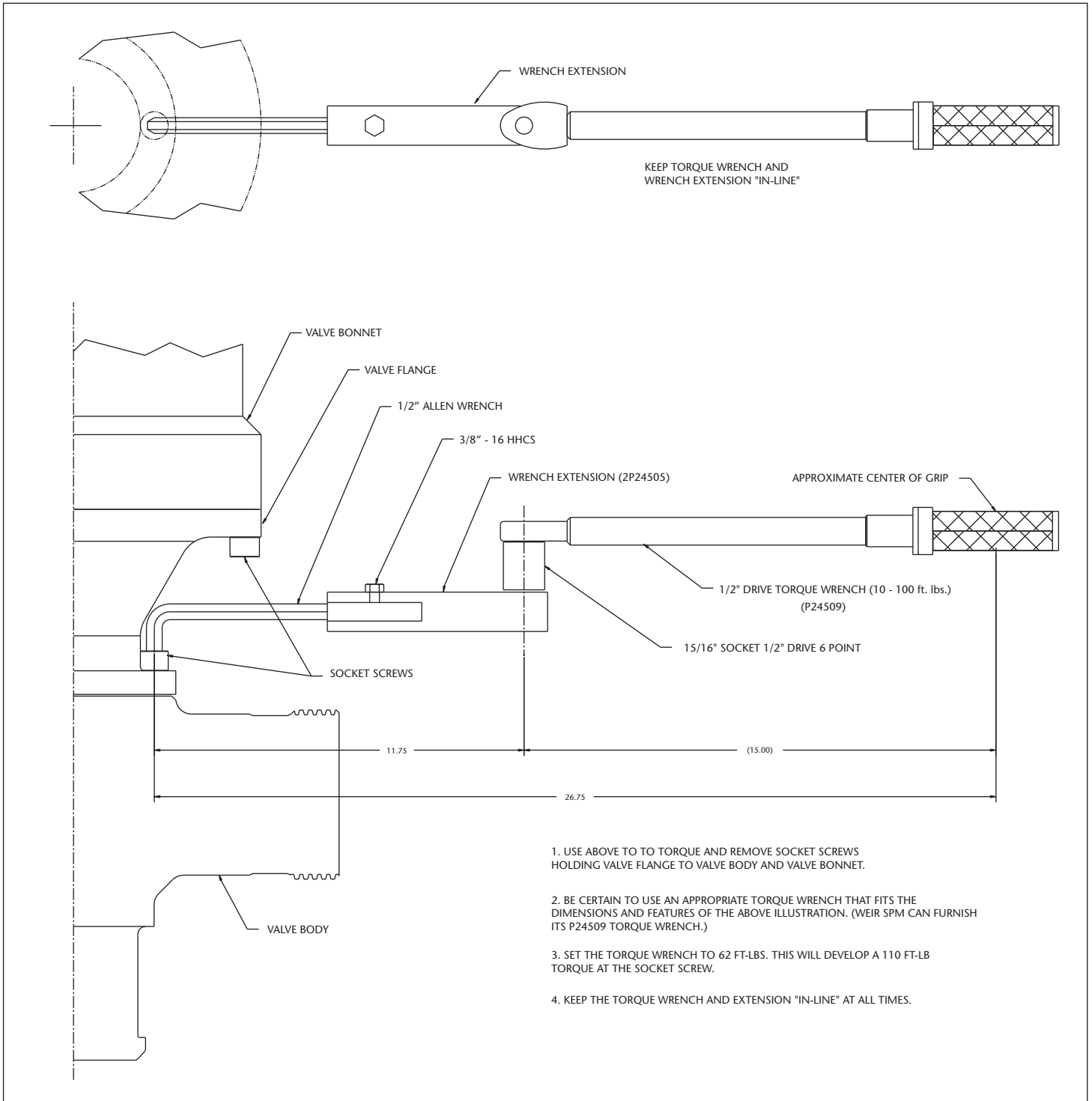

FIG. 6

VESSEL TEST PROCEDURE FOR 3" AND 4" N2 EMERGENCY RELIEF VALVES

**! WARNING:
INCORRECT
TESTING
PROCEDURE**

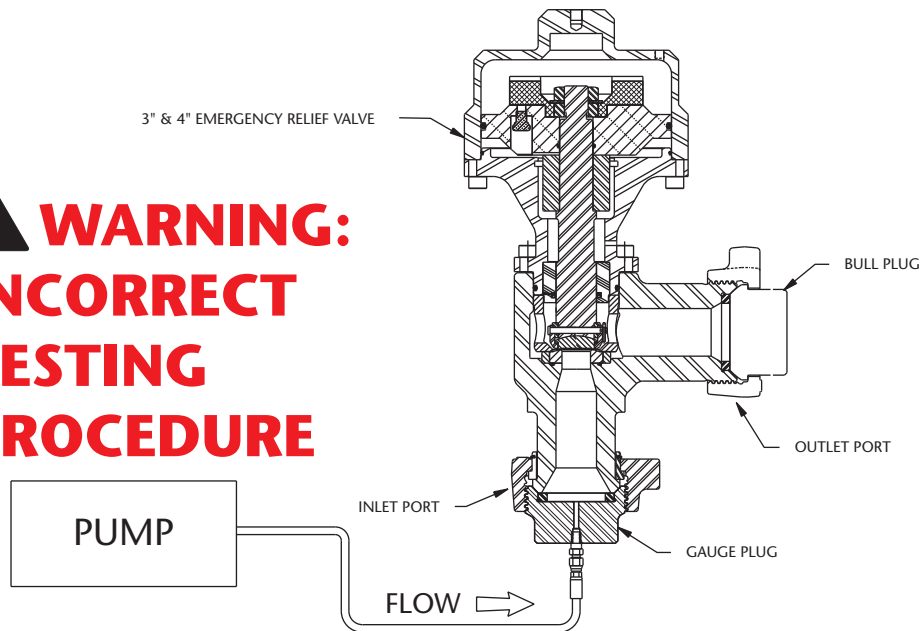

FIGURE 7. EXAMPLE OF IMPROPER TESTING
SET UP OF EMERGENCY RELIEF VALVE

➔ NEVER BLANK OFF OUTLET PORT ➔

**CORRECT
TESTING
PROCEDURE**

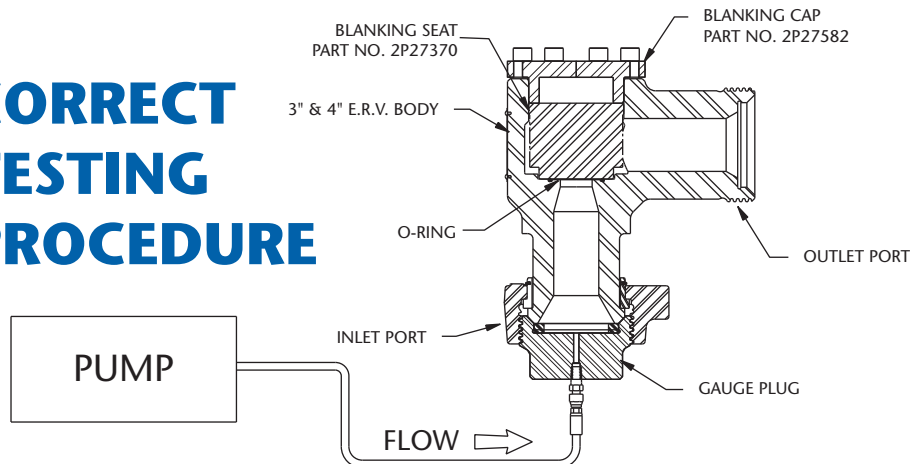

FIGURE 8. EXAMPLE OF PROPER TESTING
SET UP OF EMERGENCY RELIEF VALVE

➔ VERIFY THAT OUTLET PORT IS OPEN ➔

**FIG. 7
and
FIG. 8**

TROUBLESHOOTING GUIDE

Always follow existing company procedure concerning identifying equipment for inspection, and removing equipment from service. The following is intended as a general guide in helping resolve most problems encountered in repairing relief valves. If problems are not covered here please contact Weir SPM for assistance at (817) 246-2461.

SYMPTOM	PROBLEM	SOLUTION
1. Rapid erosion	<ul style="list-style-type: none"> a) Used as continuous bypass b) Used beyond rated capacity 	<ul style="list-style-type: none"> a) Use only as an emergency back pressure relief device b) Install sufficient quantity of valves to meet capacity requirements
2. Shuddering (Rapid opening and closing)	<ul style="list-style-type: none"> a) System pressure hovering at set pressure b) Back pressure relief valve located too close to pump's discharge c) Valve installed before pressure dampener 	<ul style="list-style-type: none"> a) Raise set pressure slightly b) Relocate relief valve. Refer to service literature for information on proper location. c) Relocate relief valve behind pressure dampener
3. Loss of pressure (Valve does not seal or loses fluid through discharge)	<ul style="list-style-type: none"> a) Valve not set properly b) Damaged nozzle or valve gate c) Damaged high pressure cylinder connection d) Contaminants trapped between valve gate and nozzle 	<ul style="list-style-type: none"> a) Set valve correctly. b) Replace damaged parts c) Replace damaged parts d) Clean affected parts
4. Valve leaks through weep hole or between valve body and cap	<ul style="list-style-type: none"> a) Damaged inner or outer or both flange seals 	<ul style="list-style-type: none"> a) Replace damaged seals
5. Valve releases higher or lower than intended relief pressure	<ul style="list-style-type: none"> a) Valve set incorrectly 	<ul style="list-style-type: none"> a) Reset valve to desired pressure per instructions in Section VIII

Parts and Seal Kit Listing

3" Emergency Relief Valve - Back Pressure - Full Bore

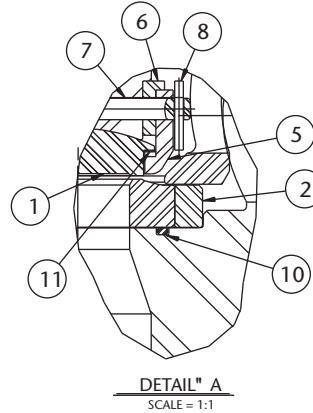
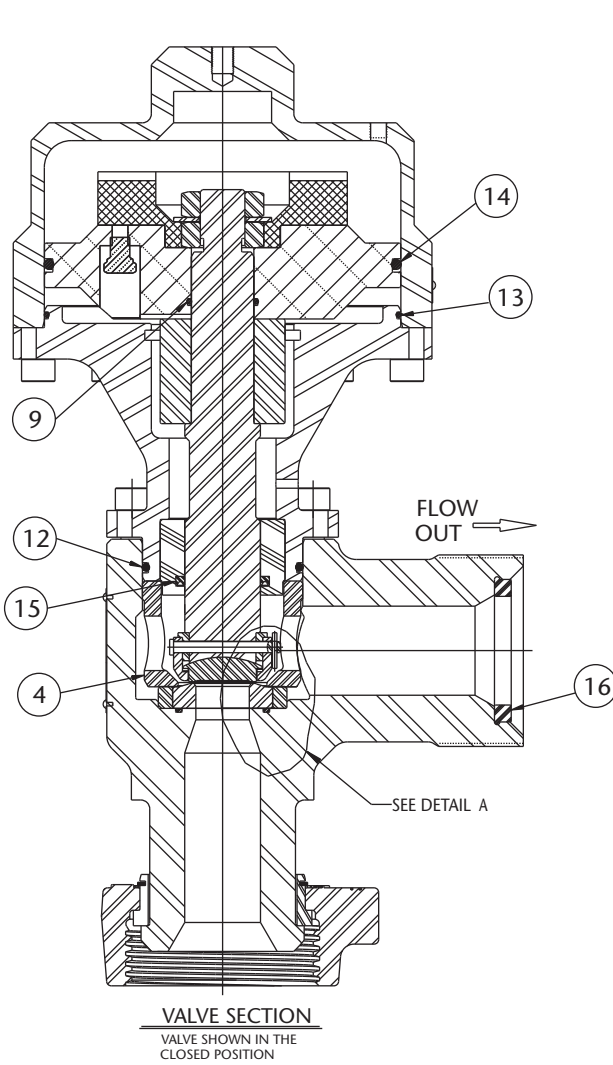

ITEM	QTY	PART NO	DESCRIPTION
16	1	"R"	SEAL RING
15	1	"Q"	CYLINDER ROD SEAL
14	1	"P"	PISTON SEAL - OUTER
13	1	"N"	FLANGE SEAL - UPPER
12	1	"M"	FLANGE SEAL - LOWER
11	1	"L"	WAVE SPRING
10	1	"K"	SEAL
9	1	"J"	PISTON SEAL - INNER
8	1	"H"	COTTER PIN
7	1	"G"	CLEVIS PIN
6	1	"F"	BUSHING
5	1	"E"	SPRING RETAINER
4	1	"D"	SPIDER
3	1	"C"	SEAT
2	1	"B"	NOZZLE
1	1	"A"	VALVE GATE

DO NOT SCALE DRAWING

UNLESS OTHERWISE NOTED
DIMENSIONS ARE IN INCHES

WEIR SPM

Linear tol: fractional ± 1/32, .XX .01, .XXX .005

Angular tol: ° 30'

All diameters concentric to Ø10 unless otherwise noted

12 \sqrt surface roughness all machined surfaces

7601 WYATT DRIVE
FT WORTH TEXAS 76108 - 2587

Scale: NONE Date: 1/22/99

Drawing by: JAS Approved: VK

DESCRIPTION:

PARTS & SEALS KIT LISTING
3" & 4" EMERGENCY RELIEF VALVE
BACK PRESSURE - FULL BORE

Material: MATERIAL Drawing No: 2L23886

SEALS KIT								
PART NO.	APPLICABLE ASSY'S	J	K	M	N	P	Q	R
4L23550	BACK PRESSURE	P23334	P23335	P16637	P23304	P23303	P23333	4P10258
4L23634	BACK PRESSURE - VITON	P23334	P19296	P10063	P23304	P23303	P24152	4P13259
2A27694	3" 20K BACK PRESS	P23334	P23334	P16637	P23304	P23303	P23333	4P22394
2A27695	3" 20K BACK PRESS - VIT	P23334	P26577	P10063	P23304	P23303	P24152	4P22395

PARTS KIT																	
PART NO.	APPLICABLE ASSY'S	A	B	C	D	E	F	G	H	J	K	L	M	N	P	Q	R
4L23548	BACK PRESSURE	3P23880	3P24314	3P23876	3P23298LT	3P23877	4P23875	P23881	P23878	P23334	P23335	P23879	P16637	P23304	P23303	P23333	4P10258
4L23632	BACK PRESSURE - VITON	3P23880	3P24314	3P23876	3P23298LT	3P23877	4P23875	P23881	P23878	P23334	P19296	P23879	P10063	P23304	P23303	P24152	4P13259
4L24315	BACK PRESSURE	3P23880	3P24314	3P23876	3P24263	3P23877	4P23875	P23881	P23878	P23334	P23335	P23879	P16637	P23304	P23303	P23333	4P10258
4L24316	BACK PRESSURE - VITON	3P23880	3P24314	3P23876	3P24263	3P23877	4P23875	P23881	P23878	P23334	P19296	P23879	P10063	P23304	P23303	P24152	4P13259
2A27692	3" 20K BACK PRESS	3P24349	2A26892		3P24263	3P23877	4P23875	P23881	P23878	P23334	P28229	P23879	P16637	P23304	P23303	P23333	4P22394
2A27693	3" 20K BACK PRESS - VIT	3P24349	2A26892		3P24263	3P23877	4P23875	P23881	P23878	P23334	P28229	P23879	P10063	P23304	P23303	P24152	4P22395
2A28338	4" 10K BACK PRESS	3P23880	3P24314		3P24263	3P23877	4P23875	P23881	P23878	P23334	P28201	P23879	P16637	P23304	P23303	P23333	4P10275
2A28339	4" 15K BACK PRESS	3P23880	3P24314		3P24263	3P23877	4P23875	P23881	P23878	P23334	P28201	P23879	P16637	P23304	P23303	P23333	4P22397
2A28340	4" 10K - 15K BACK PRESS - VIT	3P23880	3P24314		3P24263	3P23877	4P23875	P23881	P23878	P23334	P28201	P23879	P10063	P23304	P23303	P24152	4P22398

METAL SEALS KIT			
PART NO.	APPLICABLE ASSY'S	A	B
4L28048	BACK PRESSURE	3P23880	3P23874
4L28049	BACK PRESSURE - VITON	3P23880	3P23874
4L28050	BACK PRESSURE	3P23880	3P24314
4L28051	BACK PRESSURE - VITON	3P23880	3P24314
2A28052	3" 20K BACK PRESS	3P24349	2A26892
2A28053	3" 20K BACK PRESS - VIT	3P24349	2A26892

Full Bore Valve Assembly

3" Emergency Relief Valve - Back Pressure - 15,000 NSCWP

4. NAME PLATE (4P18295) TO BEAR:
- ASSY P/N
 - MFG DATE
 - SERIAL NO.
 - PRESSURE RANGE

- NOTES:
- INSTALLING BLUE LOCTITE.
 - PRESSURE RANGE: 0 - 15,000PSI
 - TORQUE BOLTS TO 110 FT-LBS

ITEM QTY	PART NO	DESCRIPTION
37	1	2P27625 WARNING LABEL
36	1	P24707 1/8" NPTPOP-OFF RELIEF VALVE
35	2	P19967 1/2"-13 NC SH55 x 3/4" LG. (S.S.)
34	2	P24708 1/2"-13 NC SH55 x 5/8" LG. (S.S.)
33	1	P24752 1 1/4" FLAT WASHER
32	1	3P24754 BUMPER
31	1	P25003 EYE BOLT
30	18	P23863 5/8-11 UNC SHCS x 1.75 LGIT
29	1	P23881 .31 x 3.00 CLEVIS PIN
28	1	P28201 SEAL
27	1	P23334 SEAL
26	1	P23333 SEAL
25	1	P23304 SEAL
24	1	P23303 SEAL
23	1	3P23880 VALVE GATE
22	2	P23299 1 1/4 - 8UN HEX JAM NUT PLAIN
21	1	3P23404 SLEEVE
20	4	P18055 DRIVE SCREW
19	1	P16637 SEAL
18	1	P10453 1/4 - 18 NPT HP PIPE PLUG
17	1	P10261 RETAINER RING
16	1	4P18295 NAME PLATE
15	1	4P10258 SEAL RING
14	1	P23879 WAVE SPRING
13	1	P23878 .125 x .75 COTTER PIN
12	1	3P23876 SEAT
11	1	3P24263 SPIDER
10	1	4P23875 BUSHING
9	1	3P23877 SPRING RETAINER
8	1	3P23292 PISTON
7	3	3P10260-III RETAINER SEGMENT - PSL
6	1	3P24314 NOZZLE ASSEMBLY
5	1	2P28045 CYLINDER
4	1	2P23884 CYLINDER ROD
3	1	2P27228 VALVE BODY
2	1	2P10257-III 3 FIG 1502 WING NUT-PSL
1	1	2A27232IT FLANGE ASSY

DO NOT SCALE DRAWING

WEIR SPM
7601 WYATT DRIVE
FT WORTH TEXAS 76108-2587

Scale: 3:8 Date: 12/12/00 Drawnby: VK Approved: MDM

Description: **FULL BORE VALVE ASSEMBLY**
3"EMERGENCY RELIEF VALVE
BACKPRESSURE-15000NSCWP

Material: 1257 surface roughness all machined surfaces

Drawing No: **2AZ3402**

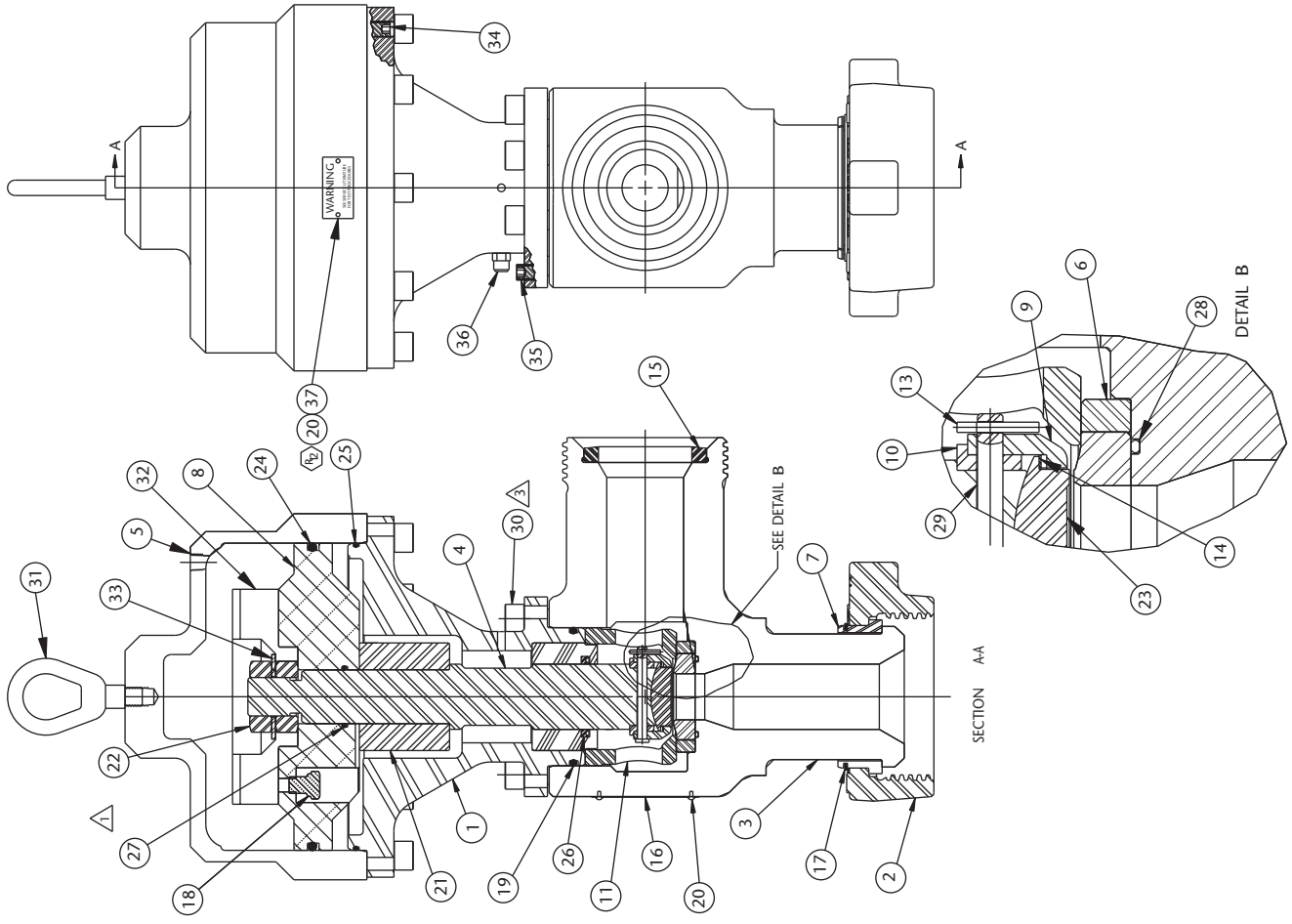

Full Bore Valve Assembly Listing

3" 20K Relief Valve - 20,000 NSCWP

NOTES:

1. INSTALL USING BLUE LOCTITE.
 2. PRESSURE RANGE: 0-20,000 PSI
 3. NAME PLATE (4P18295) TO BEAR:
 - a) ASSY P/N
 - b) MFG. DATE
 - c) SERIAL NO.
 - d) PRESSURE RANGE
- △ ALTERNATE VALVE BODY: 2P24346
 △ TORQUE BOLTS TO 110 FT-LBS.

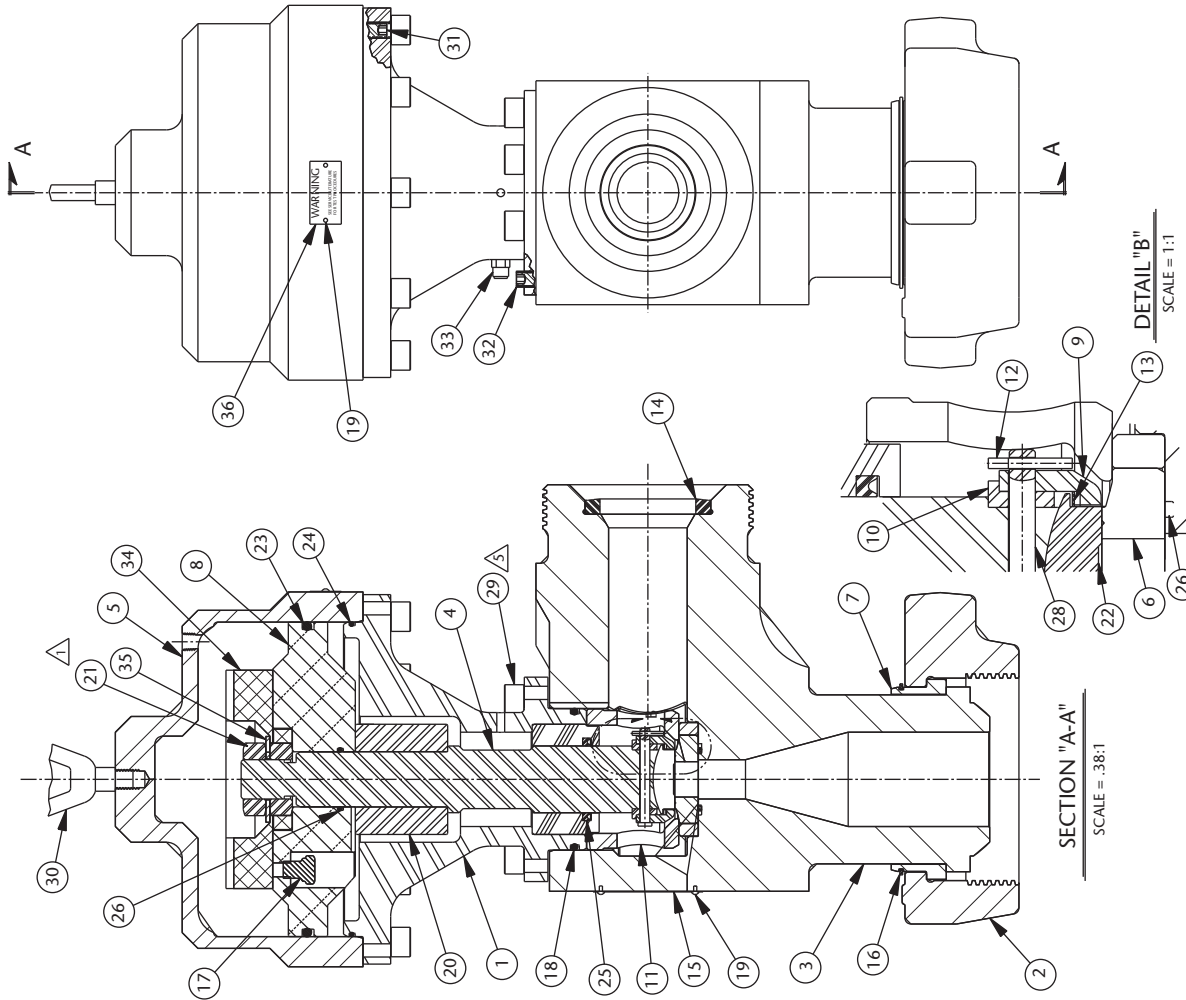

ITEM	QTY	DESCRIPTION
36	1	2P27625 WARNING LABEL
35	1	P24752 1 1/4" FLAT WASHER
34	1	3P24754 BUMPER
33	1	P24707 1/8" NPT POP-OFF RELIEF VALVE
32	2	P19967 1/2" - 13NC SHSS x 3/4" (L.G. S.S.)
31	2	P24708 1/2" - 13NC SHSS x 5/8" (L.G. S.S.)
30	1	P25003 EYEBOLT
29	18	P23863 5/8 - 11 UNC SHCS x 1.75LGLT
28	1	P23881 .31 x 3.00 CLEVIS PIN
27	1	P101241 SEAL
26	2	'D' SEAL
25	1	'C' SEAL
24	1	P23304 SEAL
23	1	P23303 SEAL
22	1	3P24349 VALVE GATE
21	1	P23299 1 1/4 - 8UN HEX JAM NUT - PLAIN
20	1	3P23404 SLEEVE
19	4	P18055 DRIVE SCREW
18	1	'B' SEAL
17	1	P10453 1/4 - 18 NPT HP PIPE PLUG
16	1	P12439 RETAINER RING
15	1	4P18295 NAME PLATE
14	1	'A' SEAL RING
13	1	P23879 WAVE SPRING
12	1	P23878 .125 x .75 COTTER PIN
11	1	3P24263 SPIDER
10	1	4P23875 BUSHING
9	1	3P23877 SPRING RETAINER
8	1	3P23292 PISTON
7	3	3P16929 RETAINER SEGMENT
6	1	2A26892 NOZZLE ASSY
5	1	2P28045 CYLINDER
4	1	2P23884 CYLINDER ROD
3	1	2P27238 VALVE BODY
2	1	2P19422 WING NUT 3" 2002
1	1	2A27232LT FLANGE ASSY
		DESCRIPTION
		PART NO

DO NOT SCALE DRAWING

WEIR SPM

UNLESS OTHERWISE NOTED
DIMENSIONS ARE IN INCHES

Linear	+ .132
XX	+ .01
XXX	+ .005
Angular	+ .30

All diameters concentric to .010 unless otherwise noted

125 surface roughness all machined surfaces

7601 WYATT DRIVE
FT WORTH TEXAS 76108-2587

Scale: .375 Drawing: JED
Date: 2/24/03 Approved: BCW

FULL BORE VALVE ASSY LISTING
3" 20K RELIEF VALVE
20,000 NSCWP

Material:
Drawing No:
2L27700

VITON	2A24348V	4P22395	P10063	P24152	P28229
BUNA	2A24348	4P22394	P16637	P23333	P28229
APPLICATION	ASSY NO.	P/N 'A'	P/N 'B'	P/N 'C'	P/N 'D'

Full Bore Valve Assembly Listing

4" 602/1002 Emergency Relief Valve - Back Pressure

4. NAME PLATE (4P18295) TO BEAR:
- ASSY P/N
 - MFG. DATE
 - SERIAL NO.
 - PRESSURE RANGE

- NOTES:
- INSTALL USING BLUE LOCTITE.
 - PRESSURE RANGE: 0-15,000 PSI
 - TORQUE BOLTS TO 110 FT-LBS

ITEM	QTY	PART NO	DESCRIPTION
37	1	2P27625	WARNING LABEL
36	1	P24707	1/8" NPT POP-OFF RELIEF VALVE
35	2	P19967	1/2"-13 NC SH55 x 3/4" LG. (S.S.)
34	2	P24708	1/2"-13 NC SH55 x 5/8" LG. (S.S.)
33	1	P24752	1/4" FLAT WASHER
32	1	3P24754	BUMPER
31	1	P25003	EYEBOLT
30	18	P23863	5/8-11 UNC SHCS x 1.75 LGIT
29	1	P23881	.31x3.00 CLEVIS PIN
28	1	P28201	SEAL
27	1	P23334	SEAL
26	1	P23333	SEAL
25	1	P23304	SEAL
24	1	P23303	SEAL
23	1	3P23880	VALVE GATE
22	2	P23299	1 1/4-8 UN HEX JAM NUT PLAIN
21	1	3P23404	SLEEVE
20	4	P18055	DRIVE SCREW
19	1	P16637	SEAL 2-346
18	1	P10453	1/4- 18 NPT HP PIPE PLUG
17	1	P10278	RETAINER RING
16	1	4P18295	NAME PLATE
15	1	4P10275	SEAL RING
14	1	P23879	WAVE SPRING
13	1	P23878	.125x.75 COTTER PIN
12	1	3P23876	SEAT
11	1	3P24263	SPIDER
10	1	4P23875	BUSHING
9	1	3P23877	SPRING RETAINER
8	1	3P23292	PISTON
7	3	3P10277	RETAINER SEGMENT
6	1	3P24314	NOZZLE ASSEMBLY
5	1	2P28045	CYLINDER
4	1	2P23884	CYLINDER ROD
3	1	'A'	VALVE BODY
2	1	'B'	WING NUT
1	1	2A27232IT	FLANGE ASSY

DO NOT SCALE DRAWING

WEIR SPM

7601 WYATT DRIVE
FT WORTH TEXAS 76108-2587

Scale: 3:8 Drawn by: TJN
Date: 11/01/05 Approved: MDM

Description: FULL BORE VALVE ASSEMBLY LISTING
4" 602/1002 EMERGENCY RELIEF VALVE
BACK PRESSURE

Material: MATERIAL Drawing No: 2L26002

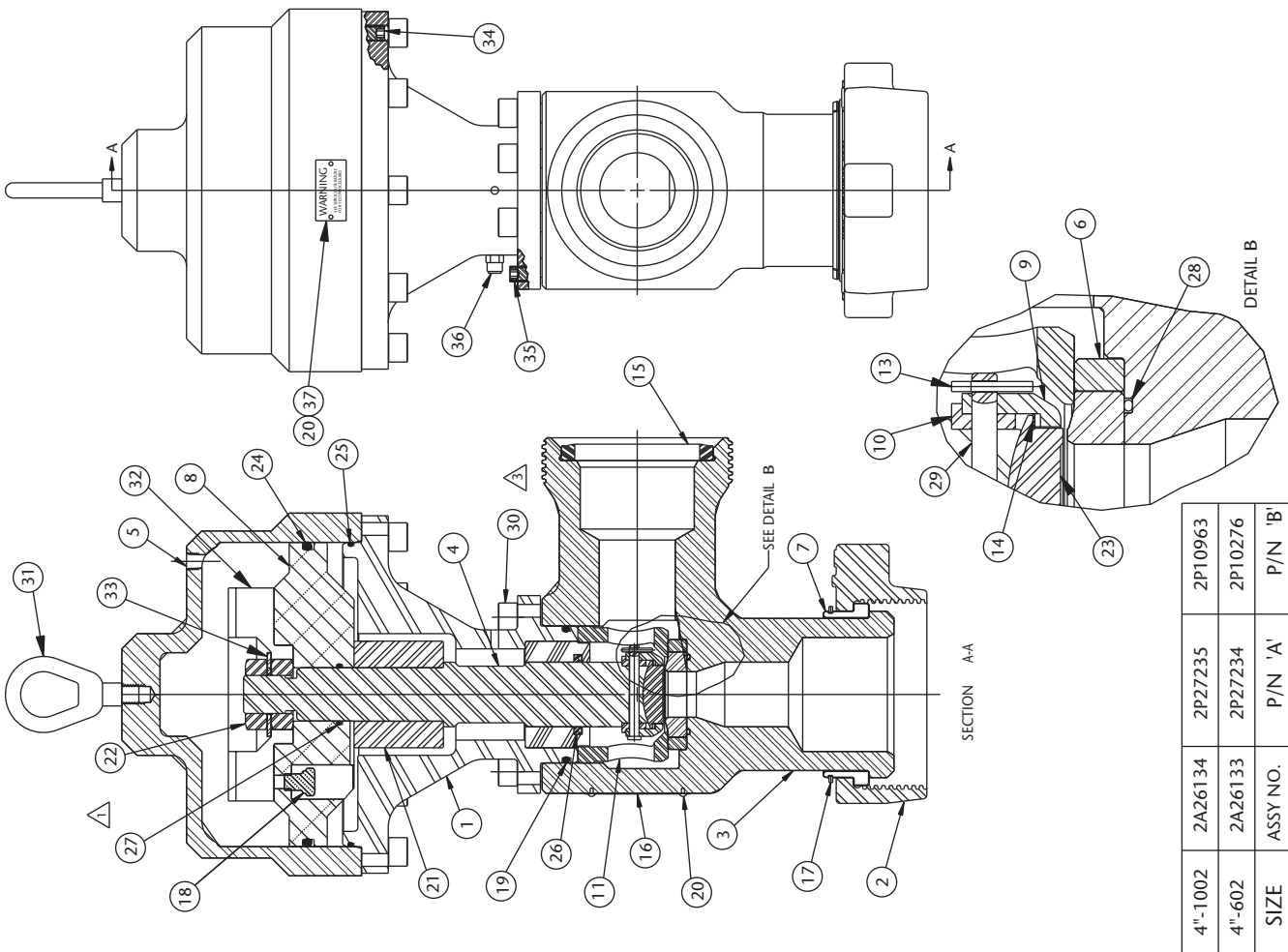

SIZE	ASSY NO.	P/N 'A'	P/N 'B'
4"-1002	2A26134	2P27235	2P10963
4"-602	2A26133	2P27234	2P10276

Full Bore - Back Pressure 4" 1502 M x F Emergency Relief Valve - 15,000 NSCW

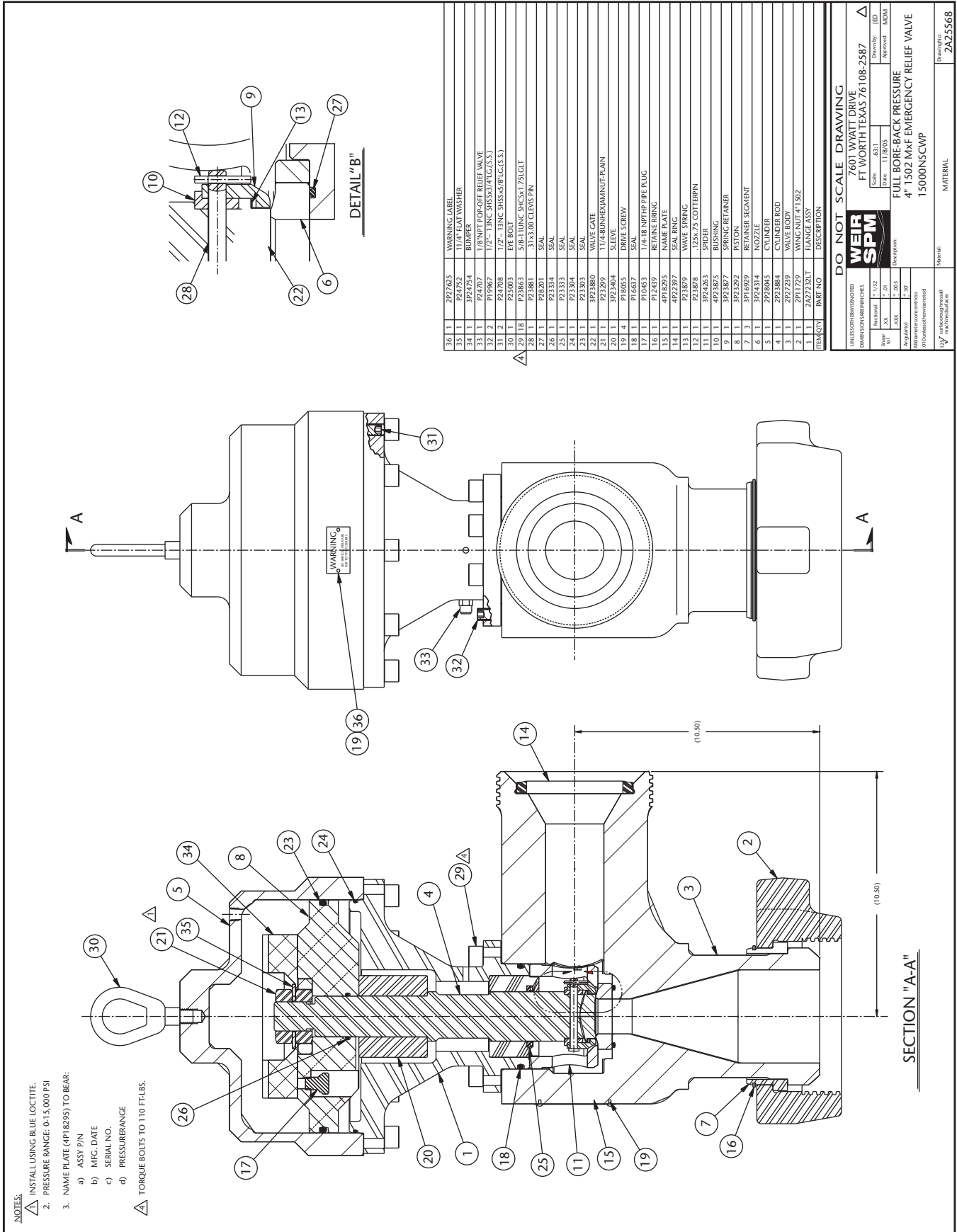

NOTES:

- 1. INSTALL USING BLUE LOCITITE.
- 2. PRESSURE RANGE: 0-15,000 PSI
- 3. NAME PLATE (4P18295) TO BEAR:
 - a) ASSY P/N
 - b) MFG. DATE
 - c) SERIAL NO.
 - d) PRESSURERANGE
- 4. TORQUE BOLTS TO 110 FT.LBS.

ITEM QTY	PART NO	DESCRIPTION
36	3P274255	WARNING LABEL
35	P24252	1/2" FLAT WASHER
34	3P24754	BUSHING
33	P24707	1/8" NPT POP-OFF RELIEF VALVE
32	P19667	1/2" - 13NC SH55X3/4 LGS.S
31	P24708	1/2" - 13NC SH55X5/8 LGS.S
30	P25003	EYE BOLT
29	P23863	5/8" TUNIC SHCS M1.75 LGLT
28	P23881	3/16" O.D. CLEVIS PIN
27	P26201	SEAL
26	P23333	SEAL
25	P23333	SEAL
24	P23304	SEAL
23	P23303	SEAL
22	3P23880	VALVE GATE
21	P23299	1 1/4" BUNTEX MANUF-PLAIN
20	3P23404	SLEEVE
19	P18055	DRIVE SCREW
18	P16657	SEAL
17	P10453	1/4" B NPT HP PIPE PLUG
16	P12859	RETAINING RING
15	P23878	WAVE SPRING
14	4P23297	SEAL RING
13	P23879	WAVE SPRING
12	P23878	.125x.75 COTTER PIN
11	3P24263	SPIDER
10	4P23875	BUSHING
9	3P23877	SPRING RETAINER
8	3P23292	PISTON
7	3P16929	RETAINER SEGMENT
6	3P24314	NOZZLE
5	3P23882	CLIP
4	3P23884	CUNDER ROD
3	2P22750	VALVE BODY
2	2P11729	WING NUT 4" 1502
1	2A27232LT	FLANGE ASSY

DO NOT SCALE DRAWING

UNLESS OTHERWISE NOTED
 DIMENSIONS ARE IN INCHES

7601 WYATT DRIVE
 FT WORTH TEXAS 76108-2587

Scale: 1" = 1.00"
 Date: 11/8/05
 Drawn by: JED
 Checked: NDAI
 Approved: NDAI

WEIR
 SPIN

Description: FULL BORE-BACK PRESSURE 4" 1502 Mx F EMERGENCY RELIEF VALVE
 15000NSCW

Material: MATERIAL

Drawing No: ZAZ5568

Full Bore Valve Assembly

4" 10K Safety Iron Emergency Relief Valve - Back Pressure - 10,000 NSCWP

- NOTES:**
- ▲ TORQUE BOLTS TO 110 FT-LBS.
 - ▲ NAME PLATE (P18295) TO BEAR:
 - a) ASSY P/N
 - b) MFG. DATE
 - c) SERIAL NO.
 - d) PRESSURE RANGE
 - ▲ INSTALL USING BLUE LOCTITE.
 - 3. PRESSURE RANGE: 0 - 10,000PSI

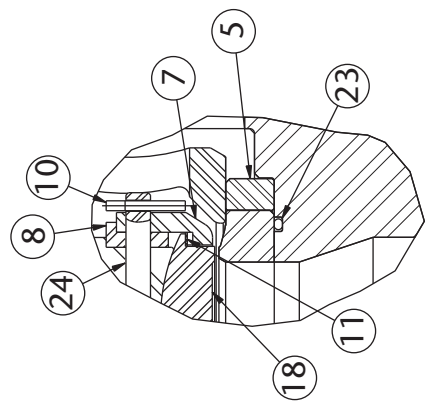

DETAIL "B"

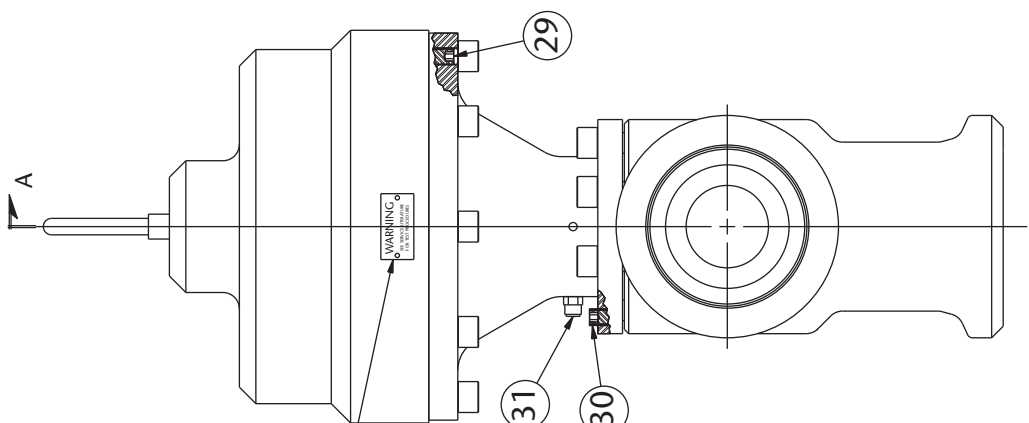

SECTION "A-A"

ITEM QTY	PART NO	DESCRIPTION
1	2A272321	FLANGE ASSY
1	2A272321	FLANGE ASSY
2	2A272327	VALVE BODY
3	2A272324	COLLAR ROD
5	2A272314	NOZZLE ASSEMBLY
6	2A272322	PISTON
7	2A272327	SPRING RETAINER
8	2A272327	BUSHING
9	2A272323	SPIDER
10	2A272323	SPIDER
11	2A272323	SPIDER
12	2A272323	SPIDER
13	2A272323	SPIDER
14	2A272323	SPIDER
15	2A272323	SPIDER
16	2A272323	SPIDER
17	2A272323	SPIDER
18	2A272323	SPIDER
19	2A272323	SPIDER
20	2A272323	SPIDER
21	2A272323	SPIDER
22	2A272323	SPIDER
23	2A272323	SPIDER
24	2A272323	SPIDER
25	2A272323	SPIDER
26	2A272323	SPIDER
27	2A272323	SPIDER
28	2A272323	SPIDER
29	2A272323	SPIDER
30	2A272323	SPIDER
31	2A272323	SPIDER
32	2A272323	SPIDER

DO NOT SCALE DRAWING

WEIR SPM
7601 WYATT DRIVE
FT WORTH TEXAS 76108-2587

4" 10K SAFETY IRON EMERGENCY RELIEF VALVE
BACK PRESSURE - 10000 NSCWP

Material: 2A27828

SAFETY INFORMATION



IMPORTANT SAFETY INFORMATION ENCLOSED. READ THIS OPERATING AND MAINTENANCE INSTRUCTIONS MANUAL BEFORE OPERATING PRODUCT.

IT IS THE RESPONSIBILITY OF THE EMPLOYER TO PLACE THE INFORMATION IN THIS MANUAL INTO THE HANDS OF THE OPERATOR. FAILURE TO READ, UNDERSTAND AND FOLLOW THE OPERATING AND MAINTENANCE INSTRUCTIONS MANUAL COULD RESULT IN SEVERE PERSONAL INJURY OR DEATH.

Weir SPM

7601 Wyatt Drive
Fort Worth
TX 76108
USA

Tel: (817) 246 2461
Fax (817) 246 6324
www.weiroilandgas.com

